

SBS SERIES

Steam

SBW SERIES

Hot Water

HEATING SYSTEMS



SBS Indoor Steam Heating System

- Space Heating
- Heating and Ventilating
- Make-Up Air
- Cooling

A MODEL FOR EVERY APPLICATION

**AIR DELIVERIES FROM
1,000 TO 92,000 SCFM**

**Heat Output to
Match Requirements**

FEATURES

**Engineered For
Easy Selection And
Proper Operation**

**All Operating And
Safety Controls For
System Selected**

**Factory Assembled
And Wired
Except For
Piping Manifold**

**Single Source
Responsibility**

**Rooftop Models
With or Without
Curbs**

**Indoor Models
Platform or
Suspended**

STEAM “SBS” AND HOT WATER “SBW” SYSTEMS

The Hastings’ SBS and SBW Series feature the package concept in steam and hot water heating systems. Either steam or hot water coils are incorporated into a factory assembled, wired and tested heating system. Six temperature control sequences are available to meet the requirements of most heating applications. In addition to the control components and dampers illustrated below, all models include motor and starter, filter section, freestat(s) and remote control station with operating switches and indicating lights.

M – MAKE-UP AIR (100% OUTSIDE AIR)

The M-Make-up Air unit is designed to replace exhausted building air with 100% outside air to prevent the many problems of “air starvation”. This replacement air is heated when the outside air is below the desired space air temperature conditions.

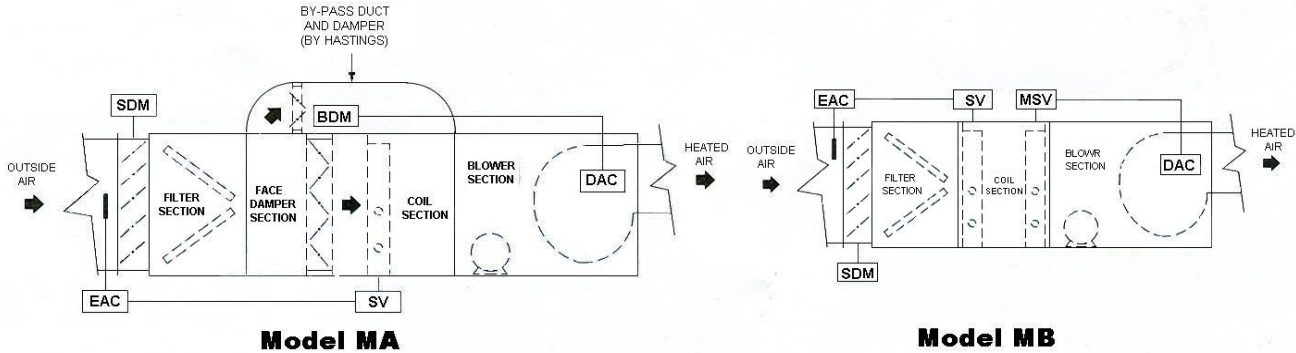

Model MA: Single coil having modulating discharge air temperature control of modulating face and by-pass damper, two position valve with mild weather air temperature lockout and inlet air shut-off damper

Model MB: Double coil having inlet air temperature control of pre-heat coil with two position valve, modulating discharge air temperature control of downstream coil with modulating valve and inlet air shut-off damper.

V – HEATING & VENTILATING (MIXED OR 100% OUTSIDE AIR)

The V-Heating & Ventilating unit combines the control of both make-up air and space air temperature. This sequence is equally effective for up to 100% of either outside or return air heating and ventilating applications, or 100% outside air only.

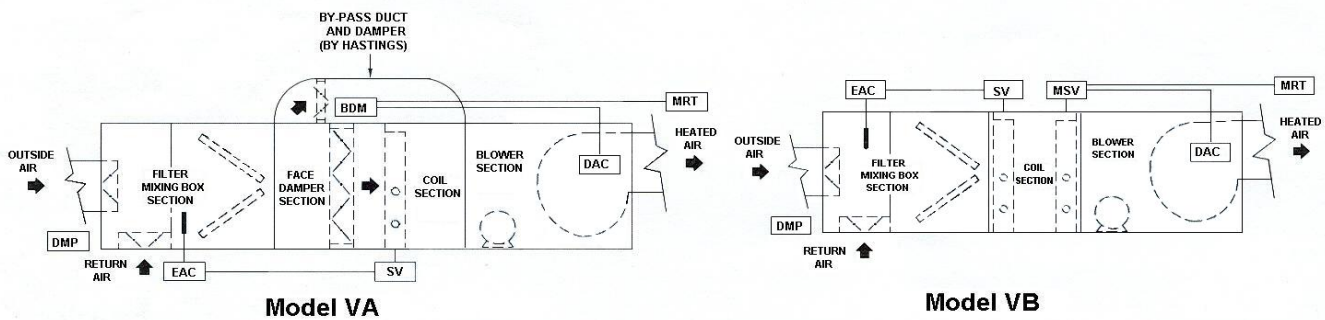

Model VA: Single coil having modulating space air temperature and over-riding discharge air temperature control of face and by-pass damper, two position valve with mild weather air temperature lockout and mixed air dampers with manual potentiometer. Inlet air shut-off damper replaces mixing dampers with 100% outside air applications.

Model VB: Double coil having inlet air temperature control of preheat coil with two position valve, modulating space air temperature and over-riding discharge air temperature control of downstream coil with modulating valve and mixed air dampers with manual potentiometer. Inlet air shut-off damper replaces mixing dampers with 100% outside air applications.

LEGEND

- | | |
|--|---|
| SV – “On-Off” Steam Valve w/Motor | EAC – Entering Air Temperature Controller (Mild Weather Lockout, MA & VA Systems) |
| MSV – Modulating Steam Valve w/Motor | BDM – Face & By-pass Damper Motor |
| RT – “On-Off” Room Thermostat | SDM – Inlet Air Shut-off Damper Motor |
| MRT – Modulating Room Thermostat | DMP – Damper Motor w/Manual Potentiometer |
| DAC – Discharge Air Temperature Controller | |
- Note:** Symbols shown for steam systems. Same controls used for hot water systems.

H – SPACE HEATING (100% RETURN AIR)

The H-Space Heating unit is designed for 100% return air space heating applications with the air temperature being controlled from the heated space. Not recommended for ventilating applications.

Model HS
STANDARD SYSTEM

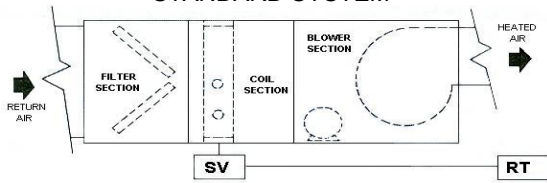

Two position space thermostat control with two position valve and choice of constant or intermittent fan operation.

Model HO
OPTIONAL SYSTEM

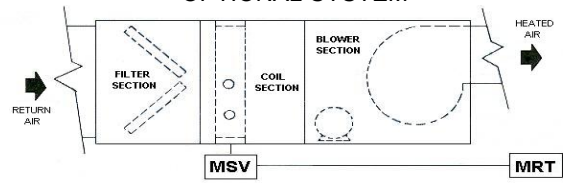

Modulating space thermostat control with modulating valve and constant fan operation.

STANDARD EQUIPMENT (All Models)

General:

Either of two horizontal blower arrangements are available as standard: HR-1, horizontal discharge and HR-2, down discharge, as illustrated below. HR-3 horizontal up-blast available.

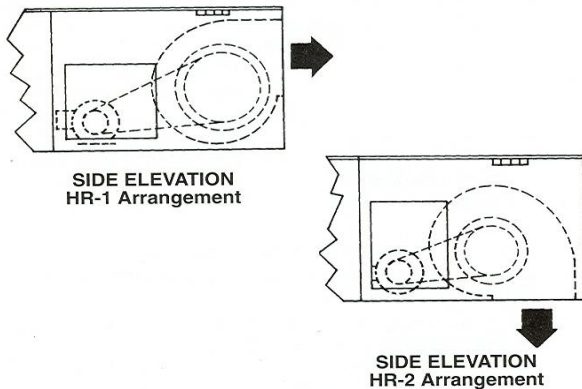

Cabinet:

Bolted construction of aluminized steel; SB-112/115 of 18 gauge, SB-215/218 of 16 gauge, SB-222/227/233 with 16/14 gauge side and 14 gauge top, and SB-240 with 14 gauge cabinet. Access panels are provided to allow easy access to motors, drivers and filters (if ordered). Outside surface is primed with zinc-chromate and finished with a coat of enamel. Cabinet interior insulated with 1"-2# density foil face insulation.

Blower:

Centrifugal forward curved, double width, double inlet, class 1 fan(s) with solid turned ground shaft and self-aligning, greaseable 200,000 hour fan bearings. All blower wheels are statically and dynamically balanced.

Blower housings, bearings and adjustable motor base are mounted on a reinforced frame to insure rigidity and quiet operation. Adjustable drives are standard through 10 HP, fixed drives with 15 HP and larger motors. V-belt drives are sized for 135% of motor horsepower.

SB-240 will have twin fan set with center coupling – Backward Incline fans standard.

Fan motors and drives are mounted within the blower cabinet. This affords motor protection and eliminates the operation hazard of V-belt drives external to the unit.

Filters:

Filter section with "V" or "Z" frames. (Filter optional)

Motor:

Premium energy efficient T-frame, open drip-proof, 1800 RPM pre-lubricated ball bearing type for all standard voltages.

Electric Controls:

- Motor Starter.
- Control transformer.
- Freezestat(s).
- NEMA 1 master control panel.
- Remote control station with system switches and indicating lights.
- All controls, dampers and motors as shown with each system sequence on pages 2 and 3 of this bulletin.

Note

Valves, valve motors and linkage, room thermostats, potentiometers and remote control stations are shipped for field piping and/or mounting and wiring.

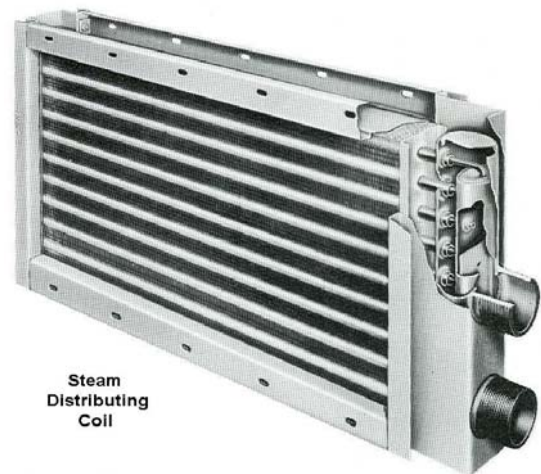

Coils:

Fabricated of heavy gauge copper tubes, staggered on 1 1/2" centers, mechanically bonded to energy efficient plate type aluminum fins. Headers are constructed of heavy seamless copper tubing and coil casings of double flanged galvanized steel. All coils tested leak free at 315 PSIG air pressure under water. Steam systems furnished with steam distributing coils having free floating cores and pitched in casing to ensure condensate drainage.

OPTIONS AND ACCESSORIES

General:

Horizontal unit blower arrangements – horizontal upflow (HR-3) available.

Vertical unit blower arrangements – three Vertical Up and three Vertical Down as illustrated below.

Components:

Weatherproof unit – for outdoor installations with insulated blower section and unit controls mounted in NEMA 3R enclosure.

Insulated coil section – available on all units.

Inlet air shut-off damper – replaces mixing dampers for 100% outside air applications on VA or VB sequences. Low leakage dampers are also available.

Stormproof weatherhood – with rainshield and birdscreen. Installed on air intake of horizontal weatherproof units. Not available with optional vertical blower arrangements.

Birdscreen – for installation on the air intake of units with optional vertical blower arrangements.

Filter section – with 2" cleanable, 2" throwaway or 2" extended surface filters. Filter section can also be insulated.

Discharge air louvers – adjustable horizontal or vertical bladed louvers are available for mounting on the blower outlet. These louvers can be combined for double deflection air control.

Service platform – with guardrail per OSHA standard. Service platforms are available for indoor horizontal units only.

Vibration isolators – either “rubber-in-shear” or “spring type” for floor mounting, roof mounting, or indoor suspension. Vibration isolators are shipped unmounted. Internal fan/motor isolation is also available.

Extended grease lines – for remote greasing of fan bearings from control side of unit.

Variable pitch sheave – for motors 15 HP and larger. Variable pitch sheaves are standard for motors 10 HP and smaller.

Motors:

Totally enclosed, two speed (10 HP and below) explosion proof and chemical duty motors are available on all units.

For two speed applications – 15 HP and above, - a field provided and installed variable speed drive is required. Furnished by others.

Coils:

- High pressure steam coils with cupro-nickel tubes.
- Copper fins.

Electric Controls:

- Clogged filter switch with indicating light.
- Automatic mixed air temperature controller.
- Low outlet temperature shut-off.
- Fused disconnect switch (dead front type) or circuit breaker mounted in cover of main control box.

Roof Curbs:

Adapter frames and roof curbs available for horizontal units. Curbs are shipped knocked down.

Miscellaneous:

Motor and controls can be mounted on opposite side. Matching cooling coil and evaporative cooling sections available for all models.

VERTICAL UNIT BLOWER DISCHARGE ARRANGEMENTS

(All sections and components are supported by special base frame and vertical support channels)

** (standard support channel heights 112 thru 218 – 24", 222 thru 233 – 26", 240-48")*

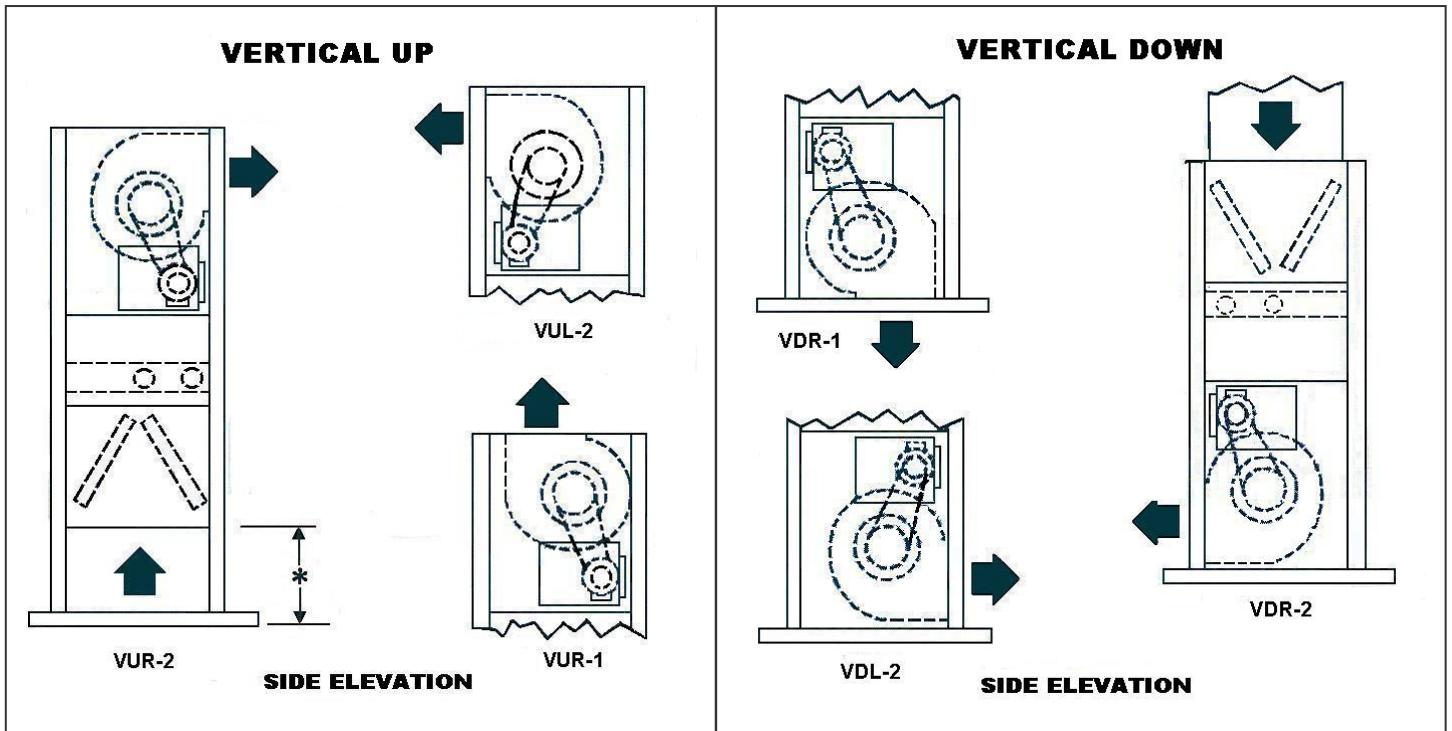

SBS STEAM DISTRIBUTING COIL SELECTION TABLE

Model	Air Delivery SCFM	Coil Face Area Sq. Ft.	Coil Face Velocity FPM	Approx. Shipping Weight Lbs.	Heating Capacity					
					One Row coil			Two Row Coil		
					MBH	Air Temp. Rise F°	Air Press. Drop In. wc	MBH	Air Temp. Rise F°	Air Press. Drop In. wc
SBS-112	1,000	2.4	417	330	86.2	78.9	.07	125.1	114.4	.11
	1,500	2.4	625	330	107.5	65.6	.14	157.5	96.0	.21
	2,000	2.4	833	330	124.6	57.0	.23	183.8	84.0	.34
	2,500	3.4	735	345	164.8	60.3	.19	242.3	88.6	.28
	3,000	3.4	882	345	180.9	55.2	.25	267.2	81.4	.38
SBS-115	4,000	5.1	784	445	254.1	58.1	.21	374.1	85.5	.32
	5,000	5.1	980	445	285.2	52.2	.31	421.7	77.1	.47
	6,000	6.7	896	470	357.2	54.4	.26	527.5	80.4	.40
	7,000	6.7	1045	470	386.7	50.5	.34	572.3	74.8	.52
SBS-215	7,000	8.2	854	890	426.9	55.8	.24	630.2	82.3	.37
	8,000	8.2	976	890	457.8	52.3	.30	676.8	77.4	.46
	9,000	10.9	826	940	558.3	56.7	.23	823.8	83.7	.35
	10,000	10.9	917	940	590.3	54.0	.27	872.0	79.7	.41
	11,000	10.9	1009	940	620.1	51.5	.32	917.1	76.2	.49
	12,000	13.6	882	990	722.2	55.0	.25	1,066.4	81.3	.39
	13,000	13.6	956	990	753.0	53.0	.29	1,113.0	78.3	.44
	14,000	13.6	1029	990	782.2	51.1	.33	1,157.3	75.6	.50
SBS-218	15,000	13.6	1103	990	810.0	49.4	.37	1,199.5	73.1	.56
	15,000	16.7	898	1210	894.5	54.5	.26	1,321.0	80.5	.40
	16,000	16.7	958	1210	925.1	52.9	.29	1,367.3	78.1	.45
	17,000	16.7	1018	1210	954.3	51.3	.32	1,411.7	75.9	.49
SBS-222	18,000	16.7	1078	1210	982.4	49.9	.36	1,454.3	73.9	.54
	18,000	19.9	905	2050	1,069.9	54.4	.27	1,580.2	80.3	.40
	20,000	19.9	1005	2050	1,129.8	51.7	.32	1,671.0	76.4	.48
	22,000	25.4	866	2120	1,333.0	55.4	.25	1,967.8	81.8	.38
	24,000	25.4	945	2120	1,395.1	53.2	.29	2,061.7	78.6	.44
	26,000	25.4	1024	2120	1,453.5	51.1	.33	2,150.5	75.6	.50
SBS-227	28,000	25.4	1102	2120	1,508.0	49.3	.37	2,212.5	72.3	.57
	28,000	30.3	924	2960	1,638.0	53.5	.28	2,432.8	79.5	.42
	30,000	30.3	990	2960	1,691.7	51.6	.31	2,523.4	76.9	.47
	32,000	36.8	870	3060	1,931.1	55.2	.25	2,859.6	81.7	.38
	34,000	36.8	924	3060	1,989.0	53.5	.28	2,954.1	79.5	.42
	36,000	36.8	978	3060	2,043.0	51.9	.30	3,040.1	77.4	.46
	36,000	36.8	1033	3060	2,093.6	50.4	.33	3,132.8	75.4	.51
	40,000	36.8	1087	3060	2,140.8	48.9	.36	3,217.4	73.6	.55
SBS-233	40,000	45.3	883	4090	2,403.6	55.0	.26	3,549.0	81.1	.39
	42,000	45.3	927	4090	2,465.7	53.7	.28	3,643.0	79.3	.42
	46,000	53.3	863	4220	2,794.0	55.5	.25	4,124.3	82.0	.38
	50,000	53.3	938	4220	2,918.8	53.4	.28	4,313.0	78.9	.43
	54,000	53.3	1013	4220	3,036.7	51.4	.32	4,491.9	76.1	.49
	58,000	53.3	1088	4220	3,148.6	49.6	.36	4,662.1	73.5	.55
SBS-240	60,000	86.0	698	7876	4,064.6	62.2	.18	5,939.7	90.9	.26
	64,000	86.0	744	7876	4,199.4	60.3	.20	6,151.1	88.3	.29
	68,000	86.0	791	7876	4,328.5	58.5	.22	6,354.1	85.8	.32
	72,000	86.0	837	7876	4,452.2	56.8	.24	6,549.4	83.5	.35
	76,000	86.0	884	7876	4,571.1	55.2	.27	6,737.5	81.4	.39
	80,000	86.0	930	7876	4,685.5	53.8	.29	6,919.0	79.4	.43
	84,000	86.0	977	7876	4,795.5	52.4	.32	7,094.4	77.6	.46
	88,000	86.0	1023	7876	4,901.9	51.2	.34	7,264.1	75.8	.50
	92,000	86.0	1070	7876	5,004.7	50.0	.37	7,428.5	74.2	.54

Capacities: Based on 10 PSIG (at coil) and 0° entering air. For other conditions apply conversion factor. Note: Assume a 20% pressure drop for a two position steam valve and a 50% drop through a modulating steam valve.

Tube wall thickness: .020 – 5 PSI or less (std.) • .025 – 15 PSI or less • .035 – 50 PSI or less • .049 – 100 PSI or less.

STEAM CONVERSION FACTORS*

Ent. Air Temp. F°	Steam Pressure At Coil – PSIG							Ent. Air Temp. F°	Steam Pressure at Coil – PSIG						
	5	10	15	20	25	30	35		5	10	15	20	25	30	35
-20	1.032	1.084	1.127	1.165	1.198	1.228	1.256	30	.823	.875	.918	.956	.989	1.019	1.047
-15	1.011	1.063	1.106	1.144	1.177	1.207	1.235	35	.802	.854	.897	.935	.968	.998	1.026
-10	.990	1.042	1.085	1.123	1.156	1.186	1.214	40	.782	.833	.876	.914	.947	.977	1.005
-5	.970	1.021	1.064	1.102	1.135	1.165	1.193	45	.761	.812	.855	.893	.926	.957	.984
0	.949	1.000	1.043	1.081	1.114	1.144	1.172	50	.740	.791	.834	.872	.906	.936	.963
5	.928	.979	1.022	1.060	1.094	1.124	1.151	55	.719	.770	.813	.851	.885	.915	.942
10	.907	.958	1.001	1.039	1.073	1.103	1.130	60	.698	.749	.792	.830	.864	.894	.921
15	.886	.937	.980	1.018	1.052	1.082	1.109	65	.677	.728	.772	.810	.843	.873	.901
20	.865	.916	.959	.997	1.031	1.061	1.089	70	.656	.708	.751	.789	.822	.852	.880
25	.844	.896	.939	.977	1.010	1.040	1.068	75	.635	.687	.730	.768	.801	.831	.859

*Minimum steam pressure (at coil) is 5 PSIG. Contact home office for information and pricing if steam pressure exceeds 30 PSIG.

SBW HOT WATER COIL SELECTION TABLE

Model	Air Delivery SCFM	Coil Face Area Sq. Ft.	Coil Face Velocity FPM	Heating Capacity									
				Two Row Coil					Four Row Coil				
				MBH	Air Temp. Rise F°	Air Press. Drop In. wc	GPM	Water Press. Drop Ft.	MBH	Air Temp. Rise F°	Air Press. Drop In. wc	GPM	Water Press. Drop Ft.
SBW-112	1,000	2.4	417	78.1	71.5	.11	7.7	.4	129.9	118.8	.21	7.7	.7
	1,500	2.4	625	100.0	60.9	.22	11.5	.8	174.8	106.6	.43	11.5	1.4
	2,000	2.4	833	117.8	53.9	.36	15.3	1.3	213.5	97.6	.71	15.3	2.3
	2,500	3.4	735	154.8	56.6	.29	19.1	1.4	276.6	101.2	.58	19.1	2.2
	3,000	3.4	882	171.4	52.2	.40	23.0	1.9	313.1	95.4	.80	23.0	3.0
SBW-115	4,000	5.0	800	244.1	55.8	.33	30.6	3.1	439.2	100.4	.66	30.6	4.7
	5,000	5.0	1000	275.7	50.4	.49	38.3	4.7	509.8	93.2	.96	38.3	7.1
	6,000	6.3	952	337.2	51.4	.45	45.9	5.1	620.3	94.5	.90	45.9	7.6
	7,000	6.3	1111	365.9	47.8	.59	53.6	6.8	685.7	89.6	1.17	53.6	10.0
SBW-215	7,000	8.1	864	415.1	54.2	.38	53.6	4.0	762.4	99.6	.75	53.6	11.9
	8,000	8.1	988	446.2	51.0	.47	61.2	5.2	832.3	95.2	.94	61.2	15.2
	9,000	10.8	833	542.5	55.1	.35	68.9	4.6	991.9	100.8	.70	68.9	9.3
	10,000	10.8	926	574.6	52.6	.42	76.5	5.6	1064.4	97.3	.84	76.5	11.2
	11,000	10.8	1019	604.8	50.3	.50	84.2	6.7	1133.0	94.2	.99	84.2	13.3
	12,000	13.5	889	702.5	53.5	.39	91.9	6.1	1294.8	98.7	.78	91.9	11.6
	13,000	13.5	963	733.7	51.6	.45	99.5	7.1	1365.3	96.0	.90	99.5	13.3
	14,000	13.5	1037	763.2	49.9	.52	107.2	8.2	1433.0	93.6	1.02	107.2	15.2
SBW-218	15,000	13.5	1111	791.4	48.3	.58	114.8	9.4	1480.6	90.3	1.15	114.8	10.6
	15,000	15.8	949	853.7	52.0	.44	114.8	8.5	1586.9	96.7	.88	114.8	15.1
	16,000	15.8	1013	883.7	50.5	.50	122.5	9.7	1635.1	93.5	.98	122.5	9.4
SBW-222	17,000	15.8	1076	912.4	49.1	.55	130.1	10.8	1700.6	91.5	1.09	130.1	10.5
	18,000	19.8	909	1056.1	53.7	.41	137.8	12.8	1926.3	97.9	.82	137.8	12.9
	20,000	19.8	1010	1117.2	51.1	.49	153.1	15.6	2064.5	94.4	.98	153.1	15.6
	22,000	25.2	873	1314.9	54.7	.38	168.4	14.2	2386.4	99.2	.76	168.4	14.4
	24,000	25.2	952	1378.1	52.5	.45	183.7	16.8	2528.3	96.3	.88	183.7	16.9
	26,000	25.2	1032	1437.9	50.6	.51	199.0	19.5	2664.0	93.7	1.02	199.0	19.6
SBW-227	28,000	25.2	1111	1486.0	48.5	.58	200.0	19.7	2746.4	89.7	1.15	214.3	13.8
	28,000	30.3	924	1632.4	53.3	.42	200.0	20.6	2953.4	96.5	.84	214.3	14.4
	30,000	30.3	990	1683.5	51.3	.48	200.0	20.6	3090.8	94.2	.95	229.6	16.4
	32,000	36.8	870	1898.7	54.3	.38	205.0	19.4	3497.7	100.0	.76	244.9	17.5
	34,000	36.8	924	1950.7	52.5	.42	205.0	19.5	3586.3	96.5	.84	260.3	8.6
	36,000	36.8	978	2000.3	50.8	.47	205.0	19.5	3724.1	94.6	.93	275.6	9.6
	38,000	36.8	1033	2047.7	49.3	.51	205.0	19.5	3857.8	92.8	1.02	290.9	10.6
SBW-233	40,000	36.8	1087	2093.0	47.9	.56	205.0	19.5	3987.8	91.2	1.11	306.2	11.6
	40,000	46.0	870	2333.4	53.3	.38	200.0	19.5	4344.8	99.3	.76	306.2	12.7
	42,000	46.0	913	2383.9	51.9	.42	200.0	19.5	4488.1	97.7	.82	321.5	13.9
	46,000	46.0	1000	2478.9	49.3	.49	200.0	19.6	4765.0	94.7	.96	352.9	16.5
	50,000	54.2	923	2892.8	52.9	.42	300.0	19.1	5321.8	97.3	.84	382.7	16.4
	54,000	54.2	996	2993.0	50.7	.48	300.0	19.1	5597.9	94.8	.96	413.3	18.9
	58,000	54.2	1070	3087.3	48.7	.55	300.0	19.2	5794.9	91.4	1.09	444.0	15.5

SBW HOT WATER COIL SELECTION TABLE CONTINUED

Model	Air Delivery SCFM	Coil Face Area Sq. Ft.	Coil Face Velocity FPM	Heating Capacity									
				Two Row Coil					Four Row Coil				
				MBH	Air Temp. Rise F°	Air Press. Drop In. wc	GPM	Water Press. Drop Ft.	MBH	Air Temp. Rise F°	Air Press. Drop In. wc	GPM	Water Press. Drop Ft.
SBW-240	69,000	82.0	732	4601.5	70.7	.28	367.0	11.7	7384.2	113.5	.56	634.0	12.8
	64,000	82.0	780	4795.1	69.1	.31	391.5	13.1	7735.5	111.5	.63	676.0	14.4
	68,000	82.0	829	4982.5	67.6	.35	416.0	14.6	8077.9	109.5	.70	718.5	16.1
	72,000	82.0	878	5163.7	66.1	.39	440.0	16.1	8411.1	107.7	.77	760.5	17.9
	76,000	82.0	927	5340.2	64.8	.42	464.5	17.7	8736.4	106.0	.85	803.0	19.8
	80,000	82.0	976	5511.8	63.5	.46	489.0	19.4	8929.2	102.9	.92	845.0	13.4
	84,000	82.0	1024	5498.7	60.4	.50	513.5	6.6	9235.6	101.4	1.01	887.5	14.7
	88,000	82.0	1073	5657.9	59.3	.54	538.0	7.2	9534.8	99.9	1.09	929.5	16.1
	92,000	82.0	1122	5813.2	58.3	.59	562.5	7.8	9828.1	98.5	1.18	972.0	17.5

Note: Use same approximate shipping weights as comparable size SBS. Capacities

Based on 180° entering hot water and 0° entering air. Water flow rates (GPM) shown were determined by selecting water temperature drops and coil circuiting resulting in efficient heat transfer values without excessive pressure drop. Contact your local Hastings sales representative for coil capacities at other conditions.

Average Steam Coil Fin Spacing Multipliers

Fins Per Inch	Heating Capacity		Air Pressure Drop	
	1-Row	2-Row	1-Row	2-Row
6	.80	.81	.88	.81
8	1.00	1.00	1.00	1.00
10	1.17	1.17	1.16	1.22
12	1.32	1.32	1.27	1.41
14	1.44	1.46	1.39	1.58

Average Hot Water Coil Fin Spacing Multipliers

Fins Per Inch	Heating Capacity		Air Pressure Drop	
	2-Row	4-Row	2-Row	4-Row
6	.82	.87	.79	.80
8	1.00	1.00	1.00	1.00
10	1.15	1.10	1.20	1.20
12	1.29	1.19	1.38	1.39
14	1.40	1.26	1.57	1.58

COIL CONNECTIONS – NPT

Steam Distributing Coils				
Model	Coil Face Area	Coil Size (Fin Surface)	Supply & Return	
			1-Row	2-Row
SBS-112	2.4	15 x 23 ½	2	2 ½
	3.4	21 x 23 ½	2	2 ½
	5.1	24 x 30 ½	2	2 ½
SBS-115	6.7	30 x 32	2	2 ½
	8.2	18 x 65 ½	2	2 ½
SBS-215	10.9	24 x 65 ½	2	2 ½
	13.6	30 x 65 ½	2	2 ½
	16.6	33 x 72 ½	2	2 ½
SBS-218	19.9	33 x 87	2	2 ½
SBS-222	25.4	42 x 87	2	2 ½
	30.3	42 x 104	2	2 ½
SBS-227	36.8	51 x 104	2 ½	2 ½
	45.3	2) 24 x 64 2) 27 x 64	(2) 2	(2) 2 ½
SBS-233	53.3	4) 30 x 64	(2) 2	(2) 2 ½
	86.0	4) 36 x 86	(4) 2	(4) 2 ½

Hot Water Coils				
Model	Coil Face Area	Coil Size (Fin Surface)	Supply & Return	
			2-Row	4-Row
SBW-112	2.3	15 x 22	2 ½	1 ½
	3.2	21 x 22	2 ½	2
SBW-115	4.8	24 x 29	2 ½	2
	6.0	30 x 29	2 ½	2
SBW-215	8.0	18 x 64	2 ½	1 ½
	10.7	24 x 64	2 ½	2
	13.3	30 x 64	2 ½	2
SBW-218	15.6	33 x 68	2 ½	2 ½
SBW-222	19.6	33 x 85 ½	2 ½	2 ½
	24.9	42 x 85 ½	2 ½	2 ½
SBW-227	30.0	42 x 103	2 ½	2 ½
	36.5	51 x 103	3*	3
SBW-233	45.7	51 x 129	3*	3
	53.8	(2) 30 x 129	(2) 2 ½	(2) 2
SBW-240	82.0	(4) 36 x 82	(4) 2 ½	(4) 2 ½

* Coil connections for single serpentine. Connection sizes could change with other circuiting.

Tube wall thickness: .020 – 5 PSI or less (std.) • .025 – 15 PSI or less • .035 – 50 PSI or less • .049 – 100 PSI or less.

MODEL DESIGNATION

SB X-XXX-X-XX

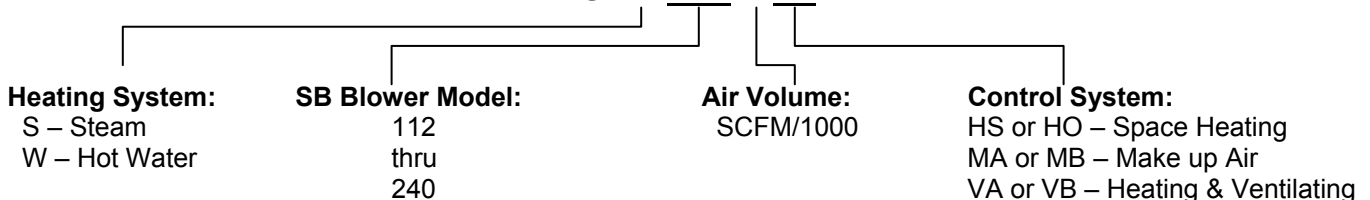

BLOWER PERFORMANCE – MOTOR HP

Model	Air Delivery SCFM	Disch. Vel. FPM	Total Static Pressure – Inches w.c. *						
			¾	1	1 ¼	1 ½	1 ¾	2	2 ½
SBS SBW-112	1000	654	¼	½	½	¾	¾	N/A	N/A
	1500	980	½	½	¾	¾	1	N/A	N/A
	2000	1307	¾	¾	1	1	N/A	N/A	N/A
	2500	1634	1	1	1 ½	1 ½	N/A	N/A	N/A
	3000	1961	1 ½	1 ½	1 ½	2	N/A	N/A	N/A
SBS SBW-115	4000	1754	1 ½	1 ½	2	2	3	3	5
	5000	2193	2	2	3	3	3	5	5
	6000	2632	3	3	5	5	5	5	5
	7000	3070	5	5	5	5	7 ½	7 ½	7 ½
SBS SBW-215	7000	1403	2	3	3	5	5	5	7 ½
	8000	1603	3	3	5	5	5	7 ½	7 ½
	9000	1804	3	5	5	5	7 ½	7 ½	10
	10000	2004	3	5	5	7 ½	7 ½	7 ½	10
	11000	2204	5	5	7 ½	7 ½	7 ½	7 ½	10
	12000	2405	5	7 ½	7 ½	7 ½	7 ½	10	10
	13000	2605	7 ½	7 ½	7 ½	7 ½	10	10	N/A
	14000	2806	7 ½	7 ½	10	10	10	10	N/A
SBS SBW-218	15000	3006	7 ½	10	10	10	10	N/A	N/A
	15000	2618	7 ½	7 ½	7 ½	10	10	10	15
	16000	2792	7 ½	7 ½	10	10	10	15	15
	17000	2967	10	10	10	10	15	15	15
SBS SBW-222	18000	3141	10	10	15	15	15	15	15
	18000	1929	10	10	15	15	15	15	20
	20000	2144	10	15	15	15	15	15	20
	22000	2358	15	15	15	15	20	20	20
	24000	2572	15	15	20	20	20	20	25
SBS SBW-227	26000	2787	15	20	20	20	20	25	25
	28000	3001	20	20	20	25	25	25	NA
	28000	1713	10	10	15	15	15	20	25
	30000	1835	10	15	15	15	20	20	25
	32000	1957	15	15	15	20	20	25	25
	34000	2080	15	15	20	20	20	25	30
SBS SBW-233	36000	2202	15	15	20	20	25	25	30
	38000	2324	15	20	20	25	25	25	30
	40000	2446	20	20	25	25	25	30	40
	40000	1888	15	15	20	20	20	25	30
	42000	1982	15	15	20	20	25	25	30
	46000	2171	20	20	20	25	25	30	40
SBS SBW-240	50000	2360	20	25	25	30	30	40	40
	54000	2548	25	25	30	30	40	40	50
	58000	2737	30	30	40	40	40	50	50
	60000	1974	20	20	25	30	30	40	N/A
	64000	2105	20	25	25	30	40	40	N/A
	68000	2237	20	25	30	30	40	40	N/A
	72000	2368	25	30	30	40	40	50	60
	76000	2500	25	30	40	40	40	50	60
	80000	2632	30	40	40	40	50	50	60
	84000	2763	30	40	40	50	50	60	75
88000	2895	40	40	50	50	60	60	75	
92000	3026	40	50	50	60	60	60	CHO	

N/A – Not Available.

* Use TSP column that will overcome total system resistance. To the coil pressure drop add the following where applicable: filters ¼", intake hood 1/8" and discharge louvers 1/8". Damper resistance may be ignored.

PREMIUM ENERGY EFFICIENT MOTOR REFERENCE TABLE (AVG.)

NOMINAL FULL-LOAD EFFICIENCY		
MOTOR HP	1800 RPM	
	Dripproof	TEFC
1	85.5	85.5
1.5	86.5	86.5
2	86.5	86.5
3	89.5	89.5
5	89.5	89.5
7.5	91.0	91.7
10	91.7	91.7
15	93.0	92.4
20	93.0	93.0
25	93.6	93.6
30	94.1	93.6
40	94.1	94.1
50	94.5	94.5
60	95.0	95.0
75	95.0	95.4
100	95.4	95.4
125	95.4	95.4

Premium Efficient motors used with a variable frequency drive produce a 4:1 reduction ratio.

MOTOR FRAME SIZE REFERENCE TABLE

MOTOR HP	MOTOR TYPE				
	1800 RPM Dripproof or TEFC	1800/900 RPM One Winding		1800/1200 RPM Two Winding	
		Dripproof	TEFC	Dripproof	TEFC
1.5	145T	145T	145T	145T	145T
2	145T	145T	145T	182T	182T
3	182T	182T	182T	184T	184T
5	184T	184T	184T	215T	215T
7.5	213T	213T	215T	254T	254T
10	21–5T	215T	215T	256T	256T
15	254T	–	–	–	–
20	256T	–	–	–	–
25	284T	–	–	–	–
30	286T	–	–	–	–
40	324T	–	–	–	–
50	326T	–	–	–	–
60	364T	–	–	–	–
75	365T	–	–	–	–
100	404T	–	–	–	–
125	405T	–	–	–	–

- Notes: 1) All motors are three phase.
 2) Motors less than 1.5 HP have frame sizes that will fit within any SB model ventilating unit cabinet.
 3) SB-240 maximum frame size, 405T. For larger frame sizes consult factory.

DIMENSIONS

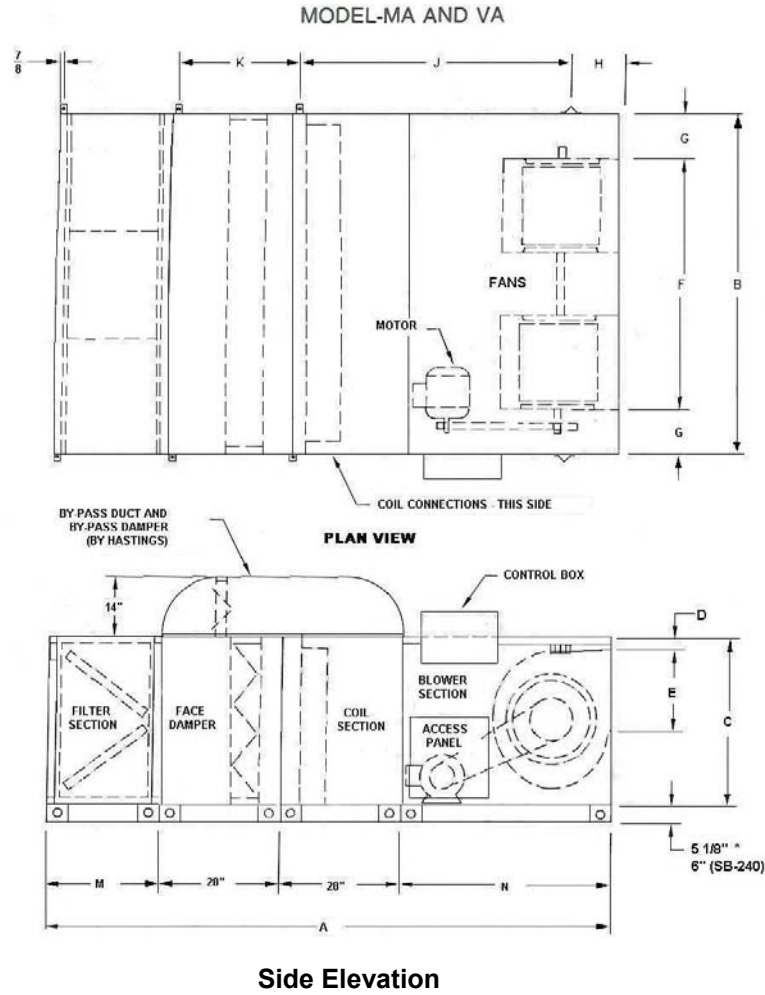

NOTES:

1. SB-112 thru SB-218 have combination lifting and hanging lugs.
 2. SB-222, SB-227, SB-233 and SB-240 have channel base frames with combination lifting and hanging lugs.
 3. Add inlet damper to Model MA.
 4. Add either mixing box or inlet damper to Model VA.
 5. By-pass duct field installed.
- * Base channel on SB-222, SB-227, SB-233 and SB-240 only.

SBS AND SBW SYSTEMS								
	112	115	215	218	222	227	233	240
A	117 7/8	125 3/4	130 1/8	131 1/8	153 1/8	169 1/8	175 1/8	-
B	33	40	75 1/8	79 1/8	96 5/8	114 3/8	141	186
C	26 1/2	35	35	39	49	58	67	80
D	2 5/8	2 5/8	2 5/8	2 5/8	4	5 3/8	4	4 3/8
E	13 1/2	16 5/8	18 1/4	18 7/8	24 1/4	34 3/8	34 1/8	42 5/8
F*	16 1/4	19 3/4	55 3/8	58 3/8	76 1/8	88 7/8	115	150 1/4
G	8 3/8	10 1/8	9 7/8	10 3/8	10 1/4	12 3/4	13	17 7/8
H	11	13 7/8	15 1/8	12 5/8	-	-	-	-
J	46 7/8	50 7/8	54	57 1/2	-	-	-	-
K	28	28	28	28	-	-	-	-
L	31 1/8	38 1/8	73 1/4	77 1/4	94 3/4	112 1/2	139 1/8	183
M	24 3/4	26	26	26	30	30 7/8	30 3/4	36
N	36 7/8	43 3/4	48 1/8	49 1/8	67 1/8	83	89 1/8	110

DIMENSIONS

MODEL-H, MB AND VB

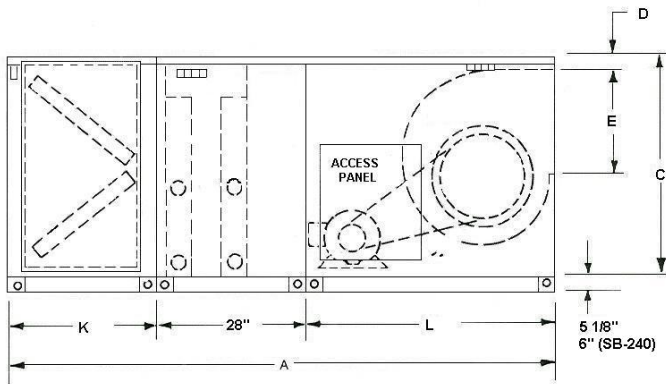
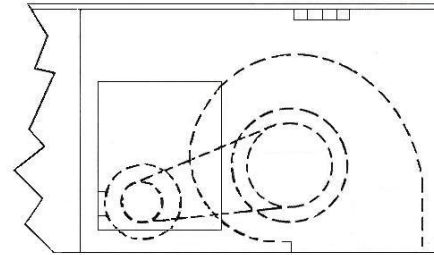
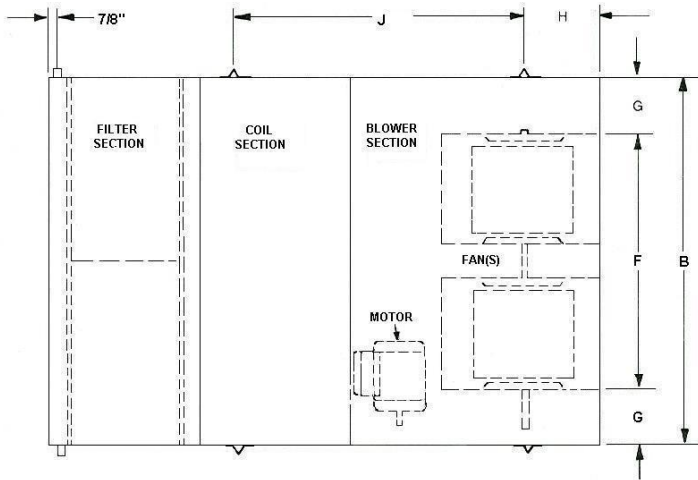

- NOTES:**
1. SB-112 thru SB-218 have combination lifting and hanging lugs.
 2. SB-222, SB-227, SB-233 and SB-240 have channel base frames with combination lifting and hanging lugs.
 3. Add inlet damper to Model MB.
 4. Add either mixing box or inlet damper to Model VB.
- * Base channel on SB-222, SB-227, SB-233 and SB-240 only.

SBS AND SBW SYSTEMS								
	112	115	215	218	222	227	233	240
A	89 5/8	97 3/4	102 1/8	103 1/8	125 1/8	141 7/8	147 7/8	174
B	33	40	75 1/8	79 1/8	96 5/8	114 3/8	141	186
C	26 1/2	35	35	39	49	58	67	80
D	2 5/8	2 5/8	2 5/8	2 5/8	4	5 3/8	4	4 3/8
E	13 1/2	16 5/8	18 1/4	18 7/8	24 1/4	34 3/8	34 1/8	42 5/8
F*	16 1/4	19 3/4	55 5/8	58 5/8	76 5/8	88 7/8	115 1/4	150 1/4
G	8 3/8	10 1/8	9 7/8	10 3/8	10 1/4	12 3/4	13	17 7/8
H	11	13 7/8	15 1/8	12 3/8	-	-	-	-
J	46 7/8	50 7/8	54	57 1/2	-	-	-	-
K	24 3/4	26	26	26	30	30 7/8	30 3/4	36
L	36 7/8	43 3/4	48 7/8	49 1/8	67 1/8	83	89 1/8	110
M	1 1/8	1 1/8	1 1/8	1 1/8	8	8	8	8

All dimensions are in inches.

* SB-112 and SB-115 have one fan. All other models have two fans.

OPTIONAL ROOF CURB

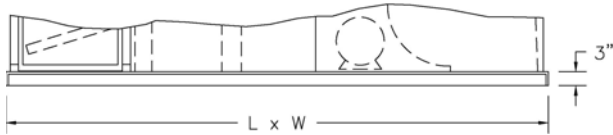
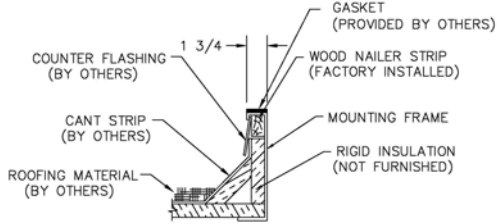

Curb Adapter Frame*					
Model		112	115	215	218
L	MA-VA Inlet Damper	123 7/8	131 1/2	135 7/8	136 7/8
	VA Mixing Box	138 7/8	150 1/4	171 7/8	172 7/8
	MB-VB Inlet Damper	95 3/8	103 1/2	107 7/8	108 7/8
	VB Mixing Box	110 7/8	122 1/4	143 7/8	144 7/8
W	All Models	34	41	76 7/8	80 7/8

All Dimensions in Inches

- Channel frame on SB-222, SB-227, SB-233 and SB-240 mounts directly to roof curb. Installation of base frame flashing recommended (Provided by others).

NOTE: Duct adapter for HR-2 curb mounted units is furnished as standard equipment when Hastings curbs are supplied.

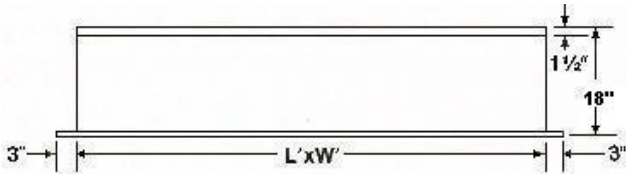

ACCESSORY ITEMS

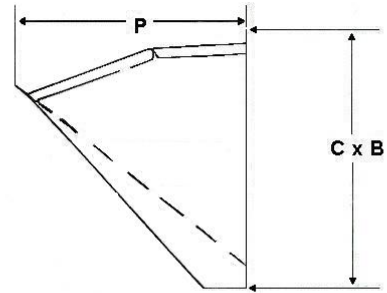

STORMPROOF WEATHERHOOD (BIRDSCREEN)

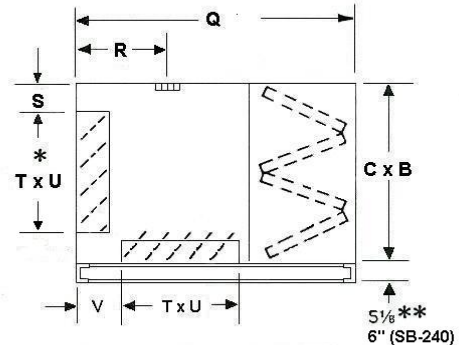

COMBINATION FILTER/MIXING BOX

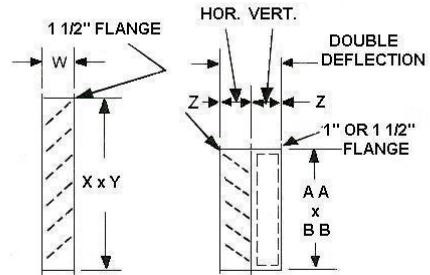

INTAKE DAMPER

DISCHARGE LOUVERS***

* Use Mixing Box Intake Damper (X x Y) for SB-222, 227, 233 & 240.

** Base Channel on SB-222, 227, 233, & 240 Only.

*** Two louvers required for SB-215 thru SB-240.

Roof Curb									
MODEL		112	115	215	218	222	227	233	240
L'	MA-VA Inlet Damper	121 7/8	130	134 3/8	135 7/8	153 3/8	167 7/8	175 7/8	202
	VA Mixing Box	136 7/8	148 3/8	170 7/8	171 7/8	199 7/8	228 7/8	244 7/8	268 7/8
	MB-VB Inlet Damper	93 7/8	102	106 3/8	107 7/8	125 3/8	141 7/8	147 7/8	174
	VB Mixing Box	108 7/8	120 3/8	142 7/8	143 7/8	171 7/8	200 7/8	216 7/8	240 7/8
W	All Models	32 1/2	39 1/2	75 5/8	78 5/8	96 5/8	114 1/2	141	186

All Dimensions in inches

SBS AND SBW SYSTEMS								
	112	115	215	218	222	227	233	240
P	35 7/8	43 3/4	43 3/4	47 1/4	56 3/8	59 3/8	58 7/8	66
Q	39 1/2	44 3/4	61 3/4	61 3/4	76 3/4	89 3/4	99 3/4	111
R	8 7/8	7	18 1/2	18 1/2	-	-	-	-
S	7 1/4	9 1/2	3	5	-	-	-	-
T	12	16	29	29	29 1/2	40 7/8	51 3/4	56 3/8
U	27	30 1/2	64	68	87 1/2	105 1/4	131 3/4	176 3/4
V	4 5/8	4 3/4	7 5/8	7 7/8	13 1/8	13 1/8	13 1/8	13 5/8
W	8 5/8	8 5/8	8 5/8	8 5/8	8 5/8	8 5/8	8 5/8	8 5/8
X	23 3/8	31 7/8	31 7/8	35 7/8	45 7/8	54 7/8	63 7/8	76 7/8
Y	29 7/8	36 7/8	72	76	93 3/8	111 1/4	137 7/8	182 7/8
Z	4	4	4	4	4	4	4	4
AA	13 1/2	16 5/8	18 1/4	18 7/8	24 1/4	34 1/4	34 1/4	42 5/8
BB	16 1/4	19 3/4	(2)19 3/4	(2)21 1/8	(2)27 3/4	(2)34 1/4	(2)44 3/4	(2)57 3/16

STEAM "SBS" AND HOT WATER "SBW" SYSTEMS

Engineers Specifications

Furnish and install the following Hastings (steam) (hot water) heating system:

Model	SCFM	Total S.P.	Motor HP	Voltage Phase	MBH Output
-------	------	------------	----------	---------------	------------

Entering Air Temp.	Leaving Air Temp.	Steam Pressure	Hot Water GPM	Entering Water Temp.	Leaving Water Temp.
--------------------	-------------------	----------------	---------------	----------------------	---------------------

Blower Section:

- A. Blower wheels shall be statically and dynamically balanced, forwardly curved, double width, double inlet, class 1. (Except SB-240 has Backward Incline fans as standard.
- B. Blower wheels shall be mounted on a solid turned ground shaft.
- C. 200,000 hour bearings shall be ball bearing, self-aligning, greaseable, pillow-block or flange mounted.
- D. Blower housings, bearings and adjustable motor base shall be mounted on a reinforced frame to insure rigidity and quiet operation.
- E. The driver and driven sheave shall be of the keyed hub type. The driven sheave shall be of a fixed pitch diameter and the driver sheave shall be of a variable pitch diameter through 10 HP and fixed pitch above 10 HP. V-belt drives shall be sized for 135% of motor horsepower.
- F. Cabinet shall be constructed of high quality (18) (16) (14) gauge aluminized steel to insure long rust-free life.
- G. Cabinet interior insulated with 1" – 2# density foil face insulation.
- H. Access panels shall be provided to allow easy access to motors and filters.
- I. Outside surface of cabinet shall be primed with zinc-chromate and finished with a coat of enamel.

Coil Section:

- A. Coils shall be fabricated of heavy gauge copper tubes, staggered on 1 1/2" centers, mechanically bonded to energy efficient plate type aluminum fins. Headers shall be constructed of heavy seamless copper tubing and coil casings of double flanged galvanized steel.
- B. All coils shall be tested leak free at 315 PSIG air pressure under water.
- C. Steam systems shall be furnished with steam distributing coils having free floating cores and pitched in casing to ensure condensate drainage.

Filter Section:

Filter section shall be an integral component of the heating system with "V" or "Z" frames.

Motor:

A Premium Energy Efficient (E+) T-frame, ODP, 1800 RPM prelubricated ball bearing type motor shall be furnished for voltage as scheduled.

Control valves are shipped by Hastings for field installation in customer's steam or hot water piping manifold. The heating coils furnished with "SBS" or "SBW" systems are subject to damage from freezing. The likelihood of this occurring can be minimized by following the instructions outlined in the installation manual.

Electric Controls:

The following controls shall be furnished:

- Motor starter.
- Control transformer.
- Freezestat(s).
- NEMA 1 master control panel.
- Remote control station with system switches and Indicating lights.

Temperature Control:

The following control sequence and control components shall be furnished with the heating system.

A. Space Heating

1. Model HS – Two position space thermostat with two position valve and choice of constant or intermittent fan operation.
2. Model HO – Modulating space thermostat with modulating valve and constant fan operation.

B. Makeup Air

1. Model MA – Single coil having modulating discharge air temperature control of modulating face and by pass damper, two position valve with mild weather air temperature lockout and inlet air shut-off damper.
2. Model MB – Double coil having inlet air temperature control of pre-heat coil with two position valve, modulating discharge air temperature control of downstream coil with modulating valve and inlet air shutoff damper.

C. Heating & Ventilating

1. Model VA – Single coil having modulating space air temperature and over-riding discharge air temperature control of face and by-pass damper, two position valve with mild weather air temperature lockout and mixed air dampers with manual potentiometer. Inlet air shut-off damper replaces mixing dampers with 100% outside air applications.
2. Model VB – Double coil having inlet air temperature control of preheat coil with two position valve, modulating space air temperature and overriding discharge air temperature control of downstream coil with modulating valve and mixed air dampers with manual potentiometer. Inlet air shut-off damper replaces mixing dampers with 100% outside air applications.

Assembly:

The system shall be factory assembled and wired with the exception of controls that are remote to the unit.

Options and Accessories:

The following items are to be furnished: **(Insert desired items from page 4 of this bulletin.)**

In order to maintain our policy of continuous product improvement, we reserve the right to change prices, specification, ratings or dimensions without notice or obligation.



3606 Yost Avenue λ Hastings, NE 68901-1966
 Phone (402) 463-9821 λ Fax (402) 462-8006
www.hastingshvac.com λ sales@hastingshvac.com

REPRESENTED BY: