



INSTALLATION AND MAINTENANCE INSTRUCTIONS

HASTINGS AIR HANDLING UNITS

INSTALLATION GUIDE:

- 1) Allow adequate clearance on both sides of unit for access to bearings, motor and internal components.
- 2) Check all set screws on motor pulley, blower pulley and blower wheel.
- 3) Check alignment of belts and pulleys. Run blower for a few minutes and adjust motor take-up if necessary. Do not over-tighten belts since excessive tension will reduce belt life and cause overheating of bearings.

Give belts a few days running time to become seated – then re-adjust take-up if necessary. Never use belt dressings.
- 4) Install canvas connectors between the unit and ductwork.
- 5) Check rotation of blower wheels and reverse power connections if wrong.
- 6) Check line voltage with motor “on” and “off” to make sure it is within 10% of the nameplate rating of motor.
- 7) Check current draw of motor to make sure it does not exceed the full load rating.

MAINTENANCE INSTRUCTIONS:

- 1) Twice a year check belts and pulleys for alignment and belt tension; make any repairs or replacements required.
- 2) Blower has greaseable bearings which allow periodic lubrication. Check bearing instructions for proper maintenance schedule.

Motor bearings vary with size and type of application. See motor instructions for proper maintenance schedule.
- 3) If a filter section is being used, check filters at least once each season, and clean or replace when necessary. In dirty environments, changing may be more frequent.

Installation and Service Manual

“IHRDV/ISHRDV/HRDV” SERIES INDOOR/OUTDOOR GAS DUCT FURNACE

Notice

Read These Instructions Before Installation

Inspect unit on arrival for any shipping damage. This furnace has been test fired for at least 15 minutes to prove out all phases of operation. If any part is missing or damaged, notify the carrier at once.



WARNING: Improper installation, adjustment, alteration, service or maintenance can cause property damage, injury or death. Read the installation, operating and maintenance instructions thoroughly before installing or servicing this equipment.

WARNING

FOR YOUR SAFETY

If you smell gas:

1. Open windows
2. Don't touch electrical switches
3. Extinguish any open flame.
4. Immediately call gas supplier

FOR YOUR SAFETY

The use and storage of gasoline or other flammable vapors and liquids in open containers in the vicinity of this appliance is hazardous.

Table of Contents

A. Purpose.....	Page 2
B. Installation Precautions.....	Pages 2 and 3
C. Installation.....	Pages 3 to 6
• Regulations	
• Location	
• Venting	
• Gas Supply	
• Electrical	
D. Electronic Ignition.....	Page 7
E. Operation.....	Pages 7
F. Trouble Shooting.....	Pages 8 to 11
G. Cleaning.....	Page 11 and 12
H. Flue Vent Arrangement Diagrams.....	Pages 13 and 14
I. Illustration.....	Page 15 & 16
J. Factory Service.....	Page 16

A. PURPOSE:

The Hastings (I) (IS) HRDV series is a complete line of duct furnaces suitable for both INDOOR or OUTDOOR APPLICATIONS. The (I) (IS) HRDV models 100-400 are design certified by A.G.A. and C.G.A. and approved for installation either upstream or downstream from cooling coils used in air conditioning systems and for applications where make-up air is specified. The purpose of this manual is to present a guide for proper installation, operation, and maintenance of the (I) (IS) HRDV furnace, and to supplement, BUT NOT TO REPLACE, the services of qualified field service personnel. This manual should be made readily available to operating personnel as an aid in maintenance and trouble shooting. If there are questions pertaining to the installation or operation of this unit, consult manufacturer.

WARNING

B. INSTALLATION PRECAUTIONS:

NOTE: GUARANTEE OF THIS EQUIPMENT IS SUBJECT TO CONFORMANCE WITH THE FOLLOWING:

1. Heater Location Requirements:
 - a. Outdoor units with poor venting, pilot outage, and other undesirable operating conditions may be caused by a negative pressure condition or high pressure zones created by walls or other obstructions. Therefore, the furnace must be located as far as possible from the source of such turbulence and at least six feet from the edge of the roof.
 - b. Indoor units must NOT be operated in the presence of CHLORINATED SOLVENTS. Even slight traces of chlorine combined with products of combustion will cause serious damage.
 - c. Indoor units must have adequate COMBUSTION AIR. If heaters are installed in a closed room, provide outside opening of one square inch per 1,000 BTU for combustion air alone.
 - d. Indoor units must not operate in an area with a negative air pressure condition. Provide adequate MAKE-UP AIR.
 - e. Indoor units installed where there is sawdust, lint, soot, dirt, etc., areas of high air contamination, must be cleaned FREQUENTLY or serious damage will result. Refer to section on CLEANING for recommended frequency.
2. WARNING: Installer/Service Technician must remove burner tray to inspect burner assemblies, to insure proper alignment. Prior to installing gas supply line to unit gas inlet, remove the "L" locking bracket and disconnect the electrical connections and slide the burner tray out of the heater. Once inspection is completed, replace the burner tray assembly and install the "L" locking bracket. **Failure to perform this inspection could result in fire, explosion, loss of warranty, or even death.**
3. Firing rate must NOT be increased above the BTU input shown on the specification plate.
4. For U.S. installations at elevations above 2,000 feet (610 M), the appliance shall be derated 4 percent for each 1,000 feet (305 M) of elevation above sea level. For Canadian installations, appliances are certified for altitudes of 0 to 2,000 feet (0-610 M) and 2,000 to 4,500 feet (610-1,370 M). High altitude ratings may be obtained by a change in orifice size and/or manifold pressure. Contact the manufacturer or gas company before changing spud sizes or pressure regulator setting. Use ½ inch socket wrench to remove spuds. NOTE: L.P. GAS UNITS ARE EQUIPPED WITH SPECIAL TAPER REAMED SPUDS WHICH MUST NOT BE RESIZED IN THE FIELD.
5. Air starvation is a common cause of heat exchanger burn out. Air handling system design MUST POSITIVELY ASSURE adequate and evenly distributed air flow through the heat exchanger. See ILLUSTRATIONS on page 15.

6. The furnace must be installed downstream from or on the POSITIVE PRESSURE SIDE of the air circulating blower
7. Air flow through the furnace may be in either direction. However, on units with an air distribution baffle assembly, the air flow must enter the furnace from the baffle side. If entering air is desired from the opposite side, the baffle assembly must be relocated to that side of the heat exchanger. High SCFM models do not require this baffle assembly and are recognized by the suffix letter "H" in the furnace model number. (Example: IHRDV-400HME).
8. High SCFM model furnaces require heating air temperature rise be maintained at between 10° to 60° F. On units with the baffle assembly temperature rise must be maintained between 40° to 100° F.
9. Filters, if used, must be cleaned or replaced as often as is necessary so as not to restrict air delivery.
10. Furnaces installed in areas of high air contamination may require FREQUENT cleaning. Refer to section on CLEANING for recommended frequency..
11. The (I) (IS) HRDV furnaces are design certified for operation with modulating or two-stage gas controls. When either modulating or two-stage controls are ordered, a thermostatic type fan control switch must NOT be used. With these gas controls, constant fan operation, simultaneous fan and gas valve operation, or a fan time delay relay must be employed.
12. If a fan control is not used, the blower must operate continuously or whenever the gas valve opens.
 NOTE: AS AN ADDED PRECAUTION, INSTALL EITHER AN AIR PROVING SWITCH OR A SINGLE POLE, NORMALLY OPEN RELAY IN THE ELECTRIC GAS VALVE CIRCUIT. THE AIR PROVING SWITCH WOULD SENSE AIR CIRCULATION THROUGH THE SYSTEM. THE RELAY WOULD BE ENERGIZED BY THE LOAD SIDE OF THE BLOWER MOTOR STARTER. EITHER SWITCH WOULD THEN ACTIVATE THE GAS VALVE TO OPEN, BUT ONLY WHEN THE BLOWER WAS OPERATING.
13. The high limit control switch is a safety control that provides protection if furnace overheats due to blower failure, restricted air flow, or faulty controls. If unit overheats the limit switch breaks the circuit to the electric gas valve and closes gas supply. When the temperature of the heat exchanger drops to a safe degree, the limit switch automatically rests and permits the gas valve to open again. Cause of trouble must be corrected IMMEDIATELY to avoid serious damage to the furnace. The limit switch is a safety control, NOT AN OPERATING CONTROL.
14. Special precautions for furnaces used in conjunction with AIR COOLING and MAKE-UP AIR SYSTEMS:
 - a. Type 409 STAINLESS STEEL heat exchangers may be used in all applications, but is recommended for make up air systems where inlet air temperature is ABOVE 40° F.
 - b. Type 321 STAINLESS STEEL heat exchangers are strongly recommended for all applications. Because of its extreme corrosion resistance, it is highly recommended for installation DOWNSTREAM from air cooling coils and must be used in make-up air systems where inlet air temperature is LESS than 40° F.
 - c. If furnace is used in either make-up air or air cooling applications, significant quantities of condensate may form.
15. Field installed ductwork on the unit discharge end must be secured to the flanges on the heat exchanger and not on unit front cabinet. **Failure to properly install could cause fire, explosion, damage to equipment or even death.**
16. Venting (I) ISHRDV indoor duct furnaces. Venting must be installed by a qualified installer in accordance with all local codes. In the absence of local codes, venting must be installed in accordance with the latest edition of the National Fuel Gas Code, ANSI Z223.1/NFPA#70, Part 7, venting of equipment. In Canada, venting must be in accordance with the latest edition of the Natural Gas Installation Code CAN/CGA-B149.1; propane installation code CAN./CGA-BA49.2. A built-in power venter is provided – do not connect into any additional mechanical draft systems operating under a positive pressure. Improper installation can create a hazardous condition such as explosion, fire, carbon monoxide poisoning, resulting in property damage, personal injury or death.

C. INSTALLATION:

• Regulations:

Installation of this appliance must conform to applicable federal, state, and local codes and regulations, and with guidelines established by A.G.A (American Gas Association), NFPA(National Fire Protection Association), N.E.C. (National Electrical Code), the National Board of Fire Underwriters and CAN/CGA B149. Listed are codes appearing in this text, the Associations, and their addresses where they may be obtained.

- | | |
|--|--|
| <ol style="list-style-type: none"> 1. The National Fuel Gas Code
 Contact: American Gas Association (Administrative)
 1515 Wilson Boulevard
 Arlington, Virginia 22209 | <ol style="list-style-type: none"> 2. All NFPA codes, National Electrical Code
 Contact: National Fire Protection Association, Inc.
 Batterymarch Park
 Quincy, Massachusetts 02269 |
| <ol style="list-style-type: none"> 3. Standard of National Board of Fire Underwriters
 Contact: National Board of Fire Underwriters
 85 John Street
 New York, New York 10036 | <ol style="list-style-type: none"> 4. Canadian Gas Association
 Contact: Canadian Gas Association
 178 Rexdale Boulevard
 Etobicoke, Ontario, Canada M9W 1R3 |

• **Location:**

NOTE: AMERICAN INSTALLATIONS MUST CONFORM WITH THE NATIONAL FUEL GAS CODE (AMERICAN NATIONAL STANDARD ANSI Z223.1 - "Latest Revisions") AND ALL APPLICABLE GOVERNING BUILDING CODES. CANADIAN INSTALLATIONS MUST CONFORM WITH CAN/CGA B149 - "Latest Revisions."

1. The (I) ISHRDV Furnace has been designed for INDOOR OR HRDV FOR OUTDOOR INSTALLATIONS.
2. Refer to items 1, 2, 5, 6, 9, 10, 12, 15, and 16 of INSTALLATION PRECAUTIONS.
3. REQUIRED MINIMUM CLEARANCES to combustible material are as follows:

CLEARANCES/INSTALLATION

Outdoor Models

The minimum clearances from combustible material are as follows:

Control Side – Width of Unit
Opposite Control Side – 6 inches
Top of Unit – Unobstructed
Discharge and Return Air Sides – 12 inches
Bottom – 0 inches
For installation downstream from refrigeration systems.

CLEARANCES/INSTALLATION

Indoor Models

The minimum clearances from combustible material are as follows:

Control Side – Width of Unit
Opposite Control Side – 6 inches
Top of Unit – 6 inches
Discharge and Return Air Sides – 12 inches
Bottom – 0 inches
For installation downstream from refrigeration systems.

* See section on ILLUSTRATIONS for dimensions of individual furnaces.

4. Install in airplane hangars in accordance with the current ANSI/NFPA 409 - "Latest Revisions", Standard on Aircraft Hangars, and in public garages in accordance with the current ANSI/NFPA BB - "Latest Revisions", Standards for Garages, and with CANI-B149 Codes. A clearance of 10 feet must be provided from the bottom of the heater to the top surface of wings or engine enclosures of the highest aircraft to be housed in the hangar and a minimum clearance of 8 feet from the door in other sections such as offices and shops connected with hangar and in public garages. Also, the heaters must be so located that they will be protected from damage by aircraft, cranes, scaffolding, etc., and must be accessible for servicing and adjustment. Standard ANSI/NFPA 88 - "Latest revisions" specifies that the heater must be so located that the clearance to combustible materials conform with NFPA Nos. 52 and 54 and that such material must not attain a temperature over 160° by continued operation of the heater.
5. If two furnaces are to be used in a side by side application, they must be installed so that the ENDS OPPOSITE the control access doors ADJOIN.
6. A 4-inch frame is an integral part of the appliance and may be installed directly on the floor or roof or other combustible construction. For ease of service and safe operation, however, it is suggested that the furnace be located above the installation surface on a field fabricated base and should be high enough to prevent any form of moisture from entering the unit.
7. Be sure that the roof joists or other obstructions will not interfere with the discharge and return air ducts.
8. The discharge and return air ducts should be correctly sized for securing to the furnace and all connections exposed to the weather must be moisture tight. A high temperature caulking (250°F) or sheet metal flashing may be used for this purpose. A weathertight seal must be provided where ducts enter through the roof. Field installed ductwork on the unit discharge end must be secured to the flanges on the heat exchanger and not on unit front cabinet. **Failure to properly install could cause fire, explosion, damage to equipment or even death.**
9. Provide tight fitting inspection panels in duct work both upstream and downstream close to the furnace. These panels must be large enough so that the heat exchanger can be easily inspected.

• **Venting:**

1. The (I) (IS) HRDV model furnace is equipped with a power venter and is complete as received.
2. No further venting of unit is required for outdoor installation (HRDV).
3. Venting is required on all indoor installations ISHRDV, and IHRDV units.
 - a. Positive pressure flue vent is recommended for installations inside building. Provide for the ISHRDV and IHRDV Series. For the requirement of positive pressure flue vent, review local codes.
 - b. Pitch vent pipe up toward outlet, 1/4" per foot for condensate drainage.
 - c. Type "B" gas vent is recommended for flue venting above roof line or external wall penetrations.
 - d. Straight vertical runs out through the roof are preferred. Vertical stack must be a minimum of five feet high.

- e. Vertical flue stacks shall be terminated with an approved cap.
- f. The maximum horizontal vent pipe length for these heaters is shown in table 1. A total equivalent horizontal vent pipe length can be calculated using equivalent straight pipe lengths for tees and elbows reducing the maximum horizontal vent pipe length by six feet for each sweep elbow, two and one half feet for termination tee, and ten feet for each short radius elbow.
- g. A gradually tapered vent pipe transition is required for (I)ISHRDV-100, (I)ISHRDV-125, and (I)ISHRDV-160 units when using 4 inch vent pipe.
- h. When possible, locate horizontal vent hoods that do not face the direction of prevailing winds to diminish the possibility of back draft situations.
- i. For U.S.A. standards vent systems must conform to the latest edition of the National Fuel Gas Code (NFPA#54) and the latest edition of NFPA #211, or as follows:
 - Not less than 7 feet above grade when located adjacent to public walk ways.
 - AT least 3 feet above any forced air inlet located within 10 feet.
 - At least 4 feet below, 4 feet horizontally from or 1 foot above any door, window or gravity air inlet into any building.
 - At least 1 foot above grade, or at least 1 foot above the normally expected snow accumulation level.
 - Directed such as to not jeopardize people.
 - At least 4 feet from electric meters, gas meters, regulators and relief equipment.
 - Sealing or shielding of exposed surfaces with a corrosion resistant material may be required to prevent staining or deterioration of building materials, and
 - Not less than 2 feet from an adjacent building.
- j. In Canada vent systems must conform to the latest edition of the Natural gas and Propane Installation Code (CAN/CGA-B149.1 or CAN/CGA-B149.2), or as follows:
 - A venting system shall not terminate underneath a veranda, porch, or deck, or above a paved sidewalk or a paved driveway that is located between two buildings, and that serves both buildings.
 - The exit terminals of mechanical draft systems shall not be less than 2.14m above grade when located adjacent to a paved sidewalk or driveway.
 - A venting system shall not direct flue gases towards brickwork, siding, or other construction, in such a manner that may cause damage from heat or condensate from the flue gases.
 - A vent system shall not direct flue gases so as to jeopardize people, overheat combustible structures, or enter buildings.
 - A venting system shall not terminate within 1.8m of the following:
 - A window, door or mechanical air supply inlet of any building, including soffit openings.
 - A gas service regulator vent outlet.
 - A combustion air inlet.
 - A property line.
 - A direction facing combustible materials or openings of surrounding buildings
 - A venting system shall not terminate within 1m of the following:
 - Above a gas meter/regulator assembly within 1m horizontally of the vertical centerline of the regulator.
 - An oil tank or an oil tankfill inlet.
 - The inside corner of an L-shaped structure.
 - A venting system shall not terminate within .3m of the following:
 - Above grade level or any surface that may support snow, ice, or debris.
 - See pages 13 AND 14 for recommended flue vent arrangements.

I(S)HRDV HORIZONTAL FLUE SIZING		
Unit Type	Flue Pipe Diameter	Maximum Length of Flue Pipe
I(S)HRDV-100	4.0 IN	82.0 FT
I(S)HRDV-125	4.0 IN	82.0 FT
I(S)HRDV-160	4.0 IN	82.0 FT
I(S)HRDV-210	6.0 IN	72.0 FT
I(S)HRDV-250	6.0 IN	72.0 FT
I(S)HRDV-300	6.0 IN	72.0 FT
I(S)HRDV-400	6.0 IN	72.0 FT

Table 1

• **Gas Supply:**

NOTE: PIPING MUST CONFORM TO STANDARDS OF THE NATIONAL BOARD OF FIRE UNDERWRITERS, CAN/CGA B149 AND ALL APPLICABLE GOVERNING CODES. INSTALL MANUAL MAIN SHUT-OFF VALVE UPSTREAM OF APPLIANCE GAS TRAIN, OUTSIDE OF THE CONFINES OF THE APPLIANCE IN ACCORDANCE WITH CURRENT INSTALLATION CODES.

1. Pipe sizing for the direct line from a N.G. meter or L.P. tank is based on a minimum 7" W.C. pressure at the meter for natural gas; minimum 12" W.C. for L.P. gas. Pipe sizes are suggested by the following table.

INPUT IN 1000'S BTU/HR.	MAXIMUM DISTANCE FROM METER	NATURAL GAS	L.P. GAS
up to 50	50 feet	1/2"	1/2"
50 to 125	40 feet	3/4"	1/2"
	100 feet	1"	3/4"
126 to 180	60 feet	1"	3/4"
	100 feet	1 1/4"	1"
181 to 250	30 feet	1"	3/4"
	120 feet	1 1/4"	1"
	200 feet	1 1/2"	1 1/4"
251 to 300	75 feet	1 1/4"	1"
	200 feet	1 1/2"	1 1/4"
301 to 400	50 feet	1 1/4"	1"
	125 feet	1 1/2"	1 1/4"

2. For larger installations or longer piping runs, consult gas company.
3. If more than 1/2 PSIG (14 in. W.C.) pressure is available, a high pressure regulator would be required. Pipe sizing may be reduced.
4. Refer to items (3) and (4) of INSTALLATION PRECAUTIONS.
5. Pipe joint compound should be resistant to the action of L.P gas.
6. Install a DIRT TRAP (tee, nipple, and cap) at connection to each furnace.
7. For ease of servicing, an additional union and manual gas valve should be installed adjacent to the furnace exterior. An approved, readily accessible manual gas valve should be joined to a ground joint type union immediately upstream and connected to the appliance manifold piping.
8. A 1/8 N.P.T. plugged tapping, accessible for test gage connection, must be installed immediately upstream of the gas supply connection to the appliance.
9. The furnace must NOT be operated without a leak limiting orifice installed in the unit pressure regulator vent, if applicable.
10. The appliance and its individual shutoff valve must be disconnected from the gas supply piping system during any pressure testing of that system at test pressures in excess of 1/2 PSIG.
11. The appliance must be isolated from the gas supply piping system by closing its individual manual shutoff valve during any pressure testing of the gas supply piping system at test pressures equal to or less than 1/2 PSIG.

NOTE: CHECK ALL GAS CONNECTIONS FOR LEAKS. A SOAP SOLUTION SHOULD BE USED FOR THIS PURPOSE. NEVER USE A TORCH OR FLAME OF ANY KIND.

• **Electrical:**

NOTE: UNIT MUST BE ELECTRICALLY GROUNDED AND ALL WIRING MUST BE DONE IN ACCORDANCE WITH THE NATIONAL ELECTRICAL CODE (ANSI/NFPA #70 - "Latest Revisions"), CSA 22.1 CANADIAN ELECTRICAL CODE AND ALL APPLICABLE GOVERNING CODES.

1. A complete wiring diagram is included with this appliance.
2. All external wiring must be run within approved weatherproof outdoor applications conduit.
3. Check specification plate on furnace for voltage and ampere requirements.
4. The power supply lines must be 14 ga. wire or larger depending on the ampere requirement of the unit.
5. If any of the original wiring or cable as supplied with the appliance is to be replaced, it must be replaced with 16 ga. AWM 6 strand 2/64 PVC 105 CUL and CSA approved wiring.
6. Refer to items 11, 12, and 13 of INSTALLATION PRECAUTIONS.
7. A non-adjustable limit control switch is attached to the heat exchanger side and is located on the control end of the furnace behind access panel.
8. The furnace thermostat must be installed according to the wiring diagram and a suitable site located to protect it from tampering and damage. Do NOT expose thermostats to jarring or physical shocks either before or after installation.

D. ELECTRONIC IGNITION:

All (I) (IS) HRDV series furnaces are equipped with a solid state design, intermittent pilot ignition system. This electronic system consists of an ignition control module, combination pilot burner/igniter-sensor (sensor or flame rod) assembly, and igniter-sensor lead. Activated by the units 24V transformer and controlled by a field installed thermostat or controller, module will first perform a safe-start check which tests its internal components for a false pilot flame condition. If satisfactory, the module then energizes the pilot gas valve to open and generates 15,000 V peak capacitive discharge ignition spark to ignite pilot burner. When pilot is established, the flame monitoring circuit of module responds to the presence of flame detected by the flame rod and discontinues ignition spark. The main gas valve is then energized to open, pilot lights main burners, and burner operation continues until call for heat is satisfied. Module then deactivates both pilot and main gas valves and unit shuts down.

Two types of ignition control modules are utilized. A non 100% shutoff design is used with natural gas ONLY. It provides continuous spark for pilot ignition, but if pilot does not light, trouble must be isolated and corrected. A 100% shutoff design may be used for natural and L.P. gas. It provides a 90 second gas trial for pilot ignition. If pilot does not light within the trial time, module deactivates pilot valve (100% safety lockout) but continues spark for pilot ignition. This system may be reset at the thermostat or controller and trial for ignition resumed. If pilot still fails to ignite, trouble must be isolated and corrected.

E. OPERATION:

*WARNING: USE CAUTION ON FOLLOWING PROCEDURES.

- *1. Purge all air from gas piping.
- *2. Carefully follow lighting instructions shown on the SPECIFICATION PLATE for electric ignition and main burner operation.
- *3. Adjust pilot burner to a quiet blue flame. Flame must surround the end of the flame rod for proper operation of the flame sensing circuit. No combustion air adjustment is required on main burners.
- *4. Pressure regulator setting must NOT be changed except under qualified supervision. If necessary, contact gas company before adjusting.
- *5. With the unit firing a maximum input, the gas line pressure should be maintained at designated inches of W.C. marked under MINIMUM SUPPLY PRESSURE on the specification plate. On multiple unit installations, each furnace should be checked in sequence. Then, with all units firing at maximum rate, the line pressure should be at least the minimum marked on the specification plate.
- *6. After the line pressure has been established, MANIFOLD PRESSURE should be as marked on the specification plate. If the unit is equipped with modulating gas controls, they must be in the HIGH FIRE POSITION when manifold pressure is read. Furnace may be severely overfired if regulator is adjusted without this precaution, and factory warranty is VOID if heaters are operated in excess of rated BTU inputs.
7. If a fan control is used, check to be sure blower starts within two minutes after gas ignition.
8. Check entering and discharge air temperature to make certain that heat rise does NOT exceed limits specified (see item 8 of INSTALLATION PRECAUTIONS) through ANY PORTION of the heat exchanger. Locate thermometers in representative temperature zones of the duct system both upstream and downstream of the furnace and to find the difference of the respective readings. The heat rise temperature may be changed by increasing blower speed to lower the temperature or by decreasing the blower speed to raise the temperature.
9. Check for proper operation of the limit switch. Refer to item 13 of INSTALLATION PRECAUTIONS.
10. To maintain proper air circulation through the heating system, twice a year check blower sheaves for alignment and belts for tension. Inspect for residual accumulation on impeller blades and follow blower manufacturer's instructions for lubrication and maintenance.

F. TROUBLE SHOOTING:

NATURE OF TROUBLE

CORRECTIVE MEASURES

• Pilot Fails to Light, Flame Burns Erratically , or Goes Out:

1. Improper (too high or low) gas pressure at unit.

Make sure all manual gas cocks are open. Check gas pressure at main valve to be certain it conforms to MINIMUM SUPPLY PRESSURE marked on the specification plate. In any case, pressure is NOT to exceed 14" W.C. for natural or L.P. gas. Regulate gas pressure or change supply pipe size to maintain proper inlet pressure. Regulate gas pressure or change supply pipe size to maintain proper inlet pressure. Adjust pilot flame to surround end of flame rod about 3/8 inch.

2. Obstruction in pilot line or orifice.

See CLEANING instructions.

3. Inoperative pilot gas valve or valve operator.

Check all manual gas cocks. Inspect wiring/connections between ignition module and pilot valve or operator. Correct as necessary. Check low voltage across PV and MV/PV terminals on module. If previous inspections are satisfactory, replace pilot valve or operator. If no or inadequate voltage is detected on module test, replace module.

4. No or inadequate spark across igniter-sensor gap.

Check for line voltage, low voltage power supply and transformer, all wiring connections, improper ground, blown fuse in ignition module if applicable, faulty high limit switch, voltage leaks in igniter lead or cracked flame rod insulator, and proper igniter-sensor gap (approximately 1/8"). Correct as necessary. If igniter still does not spark, replace ignition module.

5. Improper pilot. Flame either too small or flame "lifts."

If pilot is too small, clean pilot line, primary air openings, and pilot orifice. If flame lifts, reduce gas pressure. For both conditions, adjust pilot flame to surround end of flame rod about 3/8". Flame must be soft and quiet.

6. System goes into "safety lockout." (100% lockout models ONLY.)

Reset thermostat/controller and try again for ignition. To reset, adjust thermostat to a point below room temperature or switch off controller. Wait for a minimum of 60 seconds then adjust thermostat above room temperature or switch controller on. If ignition is not made within the 90 second trial period, the system goes into safety lockout again. Check gas supply, line and low voltage supply, ground limit switch, all wiring/connections, ignitions module and gas valves. Correct as necessary.

• Venter Running But No Spark Or Pilot

1. Vent proving switches not made.

Replace Venter motor (end switch).
Replace vent proving air switch.
Improve venting practices.
Improve on negative pressure in room.
Replace ignition wire.
Replace ignition control module.

NATURE OF TROUBLE

CORRECTIVE MEASURES

• Pilot Lights But Ignition Spark Continues:

1. Pilot flame does not contact flame rod sufficiently.
2. Faulty flame rod, igniter lead, ground wire/connections, or inoperative ignition module.

Adjust pilot to surround end of flame rod about 3/8". Flame must be soft and quiet.

If a problem develops in the flame sensing circuit, pilot flame may NOT be detected to conduct a flame sensing current even though high voltage ignition spark is satisfactory. If the flame rod is faulty and cleaning does not correct, the igniter/burner assembly must be replaced. Inspect and correct as necessary igniter lead and ground wire/connections. If ignition continues to spark, replace module.

• Main Burners Fail to Light:

1. Faulty limit switch. Stuck in open position.
2. Pilot flame too small
3. Improper (too high or low) gas pressure at unit.
4. Faulty flame rod, igniter lead, ground wire/connections, or inoperative ignition module.
5. Inoperative main gas valve.

Replace limit switch

See item 5 of "Pilot Fails to Light" in this section.

See item 1 of "Pilot Fails to Light" in this section.

See item 2 of "Pilot Lights But Ignition Spark Continues" in this section. To test ignition module, check low voltage across MV and MV/PV terminals. If no or inadequate voltage is detected, replace module. If voltage is satisfactory, inspect main gas valve.

Check all wiring/connections between ignition module and main gas valve and correct as necessary. If module and wiring inspections are satisfactory, replace main gas valve or valve operator.

• Main Burners Shutdown Before Call for Heat Is Satisfied:

1. Faulty limit switch.
2. Interrupted gas supply to unit or faulty main gas valve.
3. Faulty system ground, flame sensing circuit, or wiring/connections.
4. System goes into "safety lockout." (100% lockout models ONLY.)
5. Faulty ignition module.

Replace limit switch.

Check gas supply. Inspect main gas valve for proper operation. Replace main valve or operator as necessary.

If ground is poor, nuisance shutdowns may occur occasionally even though burner operation is normal at the time of an inspection. Test continuity of igniter lead and ignition module ground wire. Correct as necessary. as necessary. Inspect flame rod. Clean or replace if needed. Check and correct wiring/connections between module and main gas valve.

See item 6 of "Pilot Fails to Light" in this section.

If all previous checks are satisfactory and burners continue to shutdown, replace module.

• Call for Heat Ends, But Main Burners Continue Operation:

1. Faulty thermostat/controller or short circuit in respective wiring.

Repair or replace

NATURE OF TROUBLE

CORRECTIVE MEASURES

2. Main gas valve stuck in open position or inoperative module.

Remove MV lead at ignition module. If valve does not close, replace valve or operator as necessary. If main gas valve and thermostat/controller are okay, replace module.

• Delayed or Rough Ignition:

1. Obstruction in main burner spuds.
2. Burners covered with foreign matter.

Remove spuds, clean, and replace.

Clean burners. See CLEANING on pages 11 and 12.

• Burner Flames Flashback and Burning at Spuds:

1. Gas input too low.
2. Burners or flue tubes covered by foreign matter.

Adjust pressure regulator or increase supply pipe size to unit. It may be necessary to consult gas company.

See CLEANING on pages 11 and 12. If faulty, consult manufacturer.

• Burner Flames Are Yellow or Tend to “Float” under Flue Tubes:

1. Gas input too high due to oversize main burner spuds or gas supply pressure in excess of 8 ounces (approximately 14” W.C.)
2. Dirty burner ribbons or flue tubes.
3. Insufficient combustion air.

Consult manufacturer for proper spud size before changing or gas company before adjusting regulator or decreasing size of supply piping to unit.

See CLEANING on page 11 and 12.

Make sure air inlets of unit are open. Clean unit. If condition still exists, see item 1 of INSTALLATION PRECAUTIONS.

• Blower Fails to Operate within 2 Minutes after Burners Ignite:

1. Faulty blower wiring/connections, motor, or fan controls.
2. Fan control set too high.
3. Thermostatic fan control.

Inspect and correct wiring/connections as necessary. Connect line voltage directly to motor. If motor operates, replace fan control if non-adjustable.

Adjust setting.

See modulating or two-stage gas controls, item 10 of INSTALLATION PRECAUTIONS.

• Insufficient Heat Delivery from Furnace:

1. Undersized spuds or manifold pressure below marking on specification plate.
2. Inadequate air delivery from blower.
3. Dirty flue tubes.

Consult manufacturer for proper spud size before changing or gas company before adjusting regulator. Be sure gas supply pipe size to unit is adequate.

Check for slipping belts and proper blower speed, plugged filters (if used), dirty blower impeller blades, or any airflow obstructions and excessive system static pressure. Correct as necessary.

Clean tubes. See CLEANING on page 10.

• Furnace Overheats or Cycles on Limit Switch:

1. Main gas valve faulty. Stuck in open position.
2. Faulty limit switch or fan control (if used).

Replace main valve or operator.

Inspect and replace as necessary.

NATURE OF TROUBLE

CORRECTIVE MEASURES

- | | |
|--|--|
| 3. Blower motor cutting out on overload. | Check for high or low voltage. Check for faulty motor or motor overload. |
| 4. Inadequate air delivery from blower. | See item 2 of "Insufficient Heat Delivery" in this section. |
| 5. Poor air flow patterns through furnace. | See ILLUSTRATIONS on page 15. |
- **Resonance on L.P. Gas Units:**
 1. Reduce gas input slightly. If condition persists, consult manufacturer.
 - **Modulating or Two-Stage Gas Controls:**
 1. Consult manufacturer.

G. CLEANING:

NOTE: SOOT, DIRT, ETC. WILL PREVENT PROPER COMBUSTION. FOR NORMAL AIR CONDITIONS, CLEAN UNIT PRIOR TO HEATING SEASON WITH A PERIODIC INSPECTION AT LEAST ONCE A MONTH THROUGHOUT THE DURATION OF THE SEASON AND CLEAN AS NECESSARY. IN HEAVILY CONTAMINATED AREAS, INSPECTION AND POSSIBLE CLEANING MAY BE REQUIRED MORE FREQUENTLY DURING THE HEATING SEASON. CLEAN FLUE TUBES, BURNERS AND PILOT BEFORE THEY BECOME BADLY FOULED.

• Cleaning Flues:

1. Outdoor units:
 - a. Remove burner drawer assembly. To accomplish, close manual gas valve to unit and break main gas supply at union. Cut furnace electrical supply. Unscrew the two quick fasteners at the bottom of the control access panel. Pull bottom of panel away slightly and allow panel to drop. Remove panel and disconnect applicable electric wiring. Remove retaining tabs at each end of the burner drawer and slide drawer assembly out of the furnace.
 - b. Remove the screws holding top panel and lift panel off.
 - c. Remove the screws from bottom flange of the collector box cover and lift cover off.
 - d. Remove the screws from bottom flange of the collector box. Remove the two screws from the venter motor support at the right heater leg and disconnect the three conductor cables at the junction box. Lift collector box off. (Power venter assembly will remain attached to the collector box.)
 - e. Lift flue baffles from tubes.
 - f. Clean the inner surfaces of flue tubes using a 1-1/2" or 1-3/4" long-handled wire brush. Clean and replace flue baffles.
 - g. Remove dirt from bottom pan and clean burners before replacing drawer assembly.
2. Indoor Units:
 - a. Disconnect exhaust flue from unit flange.
 - b. Disconnect separated combustion air flue from unit flange (ISHRDV models only).
 - c. Remove the (4) screws holding the top portion of the burner control vestibule door around the power venter outlet.
 - d. Remove burner control vestibule door by turning bottom latches on door.
 - e. Pull the door away by pulling the bottom rail on the door outward.
 - f. On some models a (2) piece door is provided. (2) screws hold the top portion of the door in place. Remove screws and remove top door portion.

- g. Remove burner drawer assembly. To accomplish, close manual gas valve to unit and break main gas supply at union. Cut furnace electrical supply. Unscrew the two quick fasteners at the bottom of the control access panel. Pull bottom of panel away slightly and allow panel to drop. Remove panel and disconnect applicable electric wiring. Remove retaining tabs at each end of the burner drawer and slide drawer assembly out of the furnace.
- h. Remove the screws holding top panel and lift panel off.
- i. Remove the screws from bottom flange of the collector box cover and lift cover off.
- j. Remove the screws from bottom flange of the collector box. Remove the two screws from the venter motor support at the right heater leg and disconnect the three conductor cables at the junction box. Lift collector box off. (Power venter assembly will remain attached to the collector box.)
- k. Lift flue baffles from tubes
- l. Clean the inner surfaces of flue tubes using a 1-1/2" or 1-3/4" long-handled wire brush. Clean and replace flue baffles.
- m. Remove dirt from bottom pan and clean burners before replacing drawer assembly.

• **Cleaning Burners:**

- 1. Burners can be removed from drawer assembly by raising front of burner, pushing burner forward against the hold-down clip until venturi end of burner is free of support. Remove burners next to pilot last and replace these burners first.
- 2. Remove ribbon cotter pin and carefully pry ribbon from slot.
- 3. Clean ribbon with brush and blow off dust.
- 4. Replace ribbon and cotter pin.
- 5. Replace burners, making certain that they seat properly in place.
- 6. Failure to re-seat burner assemblies properly could result in fire, explosion, equipment damage or death.

• **Cleaning Pilot:**

- 1. Disconnect tubing from pilot body, remove igniter lead and detach pilot burner assembly from support.
- 2. Remove pilot orifice fitting.
- 3. Using a small brush, clean pilot burner assembly, orifice, and flame rod. Blow off loose particles.
- 4. Assemble and install in original position.
- 5. Adjust pilot flame to surround flame rod tip about 3/8". Flame must be soft – not hard, noisy, or yellow.

INDOOR WITH SEPERATED COMBUSTION

INSTALLATION

**VERTICAL/HORIZONTAL
FLUE PIPE**



IF EXHAUST FAN IS USED DURING THE HEATING SEASON
PROVIDE ADEQUATE "MAKE-UP" AIR AND COMBUSTION
AIR.

INSTALL IN AIRPLANE HANGARS IN ACCORDANCE WITH
CURRENT NFPA NO. 409 STANDARD ON AIRCRAFT HANGARS
AND IN PUBLIC GARAGES IN ACCORDANCE WITH CURRENT
NFPA NO. 88 STANDARD FOR GARAGES. SEE PAGE 4 FOR
DETAILS.

**CLEARANCES/INSTALLATION
INDOOR MODELS**

THE MINIMUM CLEARANCES FROM COMBUSTIBLE MATERIAL ARE AS FOLLOWS

CONTROL SIDE	-	WIDTH OF UNIT
OPPOSITE CONTROL SIDE	-	6 INCHES
TOP OF UNIT	-	6 INCHES
BOTTOM	-	0 INCHES

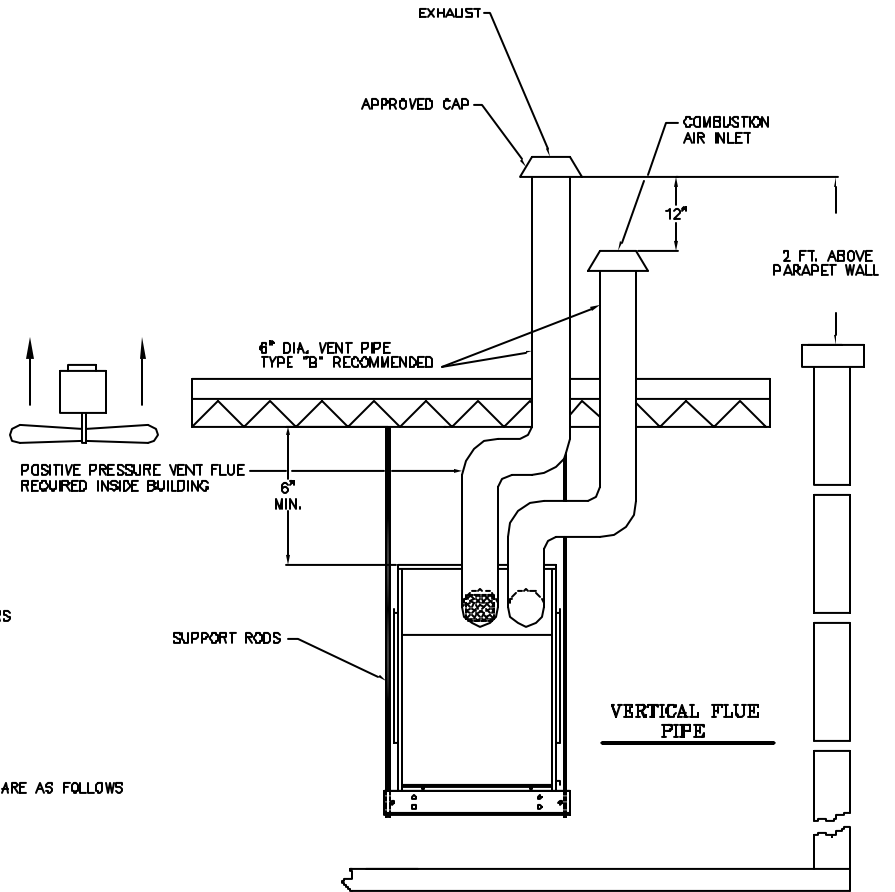

**HORIZONTAL FLUE
PIPE**

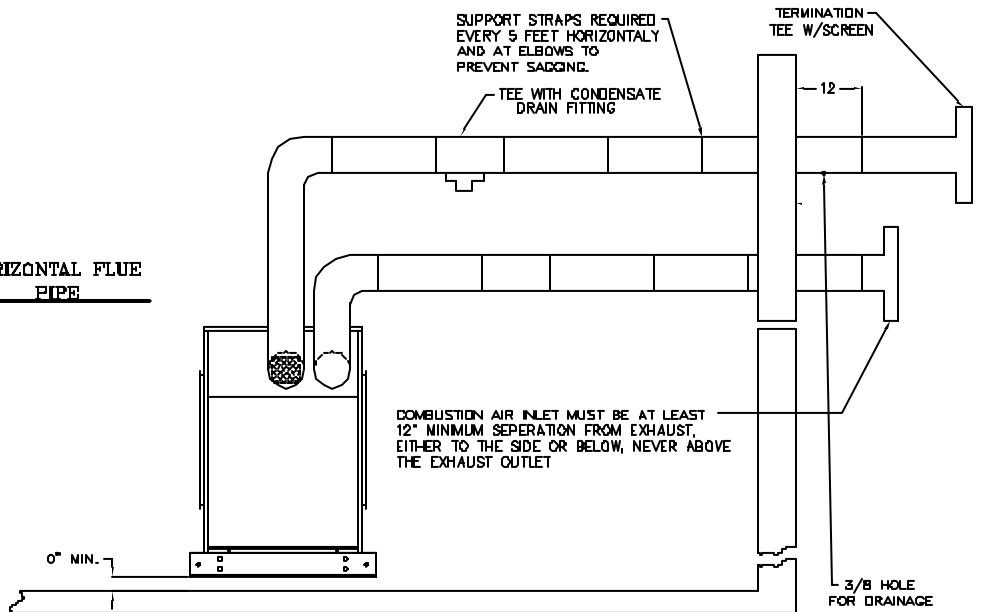

INDOOR HEATER

INSTALLATION VERTICAL/HORIZONTAL FLUE PIPE

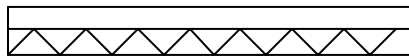

IF EXHAUST FAN IS USED DURING THE HEATING SEASON
PROVIDE ADEQUATE "MAKE-UP" AIR AND COMBUSTION
AIR.

INSTALL IN AIRPLANE HANGARS IN ACCORDANCE WITH
CURRENT NFPA NO. 409 STANDARD ON AIRCRAFT HANGARS
AND IN PUBLIC GARAGES IN ACCORDANCE WITH CURRENT
NFPA NO. 88 STANDARD FOR GARAGES. SEE PAGE 4 FOR
DETAILS.

CLEARANCES/INSTALLATION INDOOR MODELS

THE MINIMUM CLEARANCES FROM COMBUSTIBLE MATERIAL ARE AS FOLLOWS

CONTROL SIDE	-	WIDTH OF UNIT
OPPOSITE CONTROL SIDE	-	6 INCHES
TOP OF UNIT	-	6 INCHES
BOTTOM	-	0 INCHES

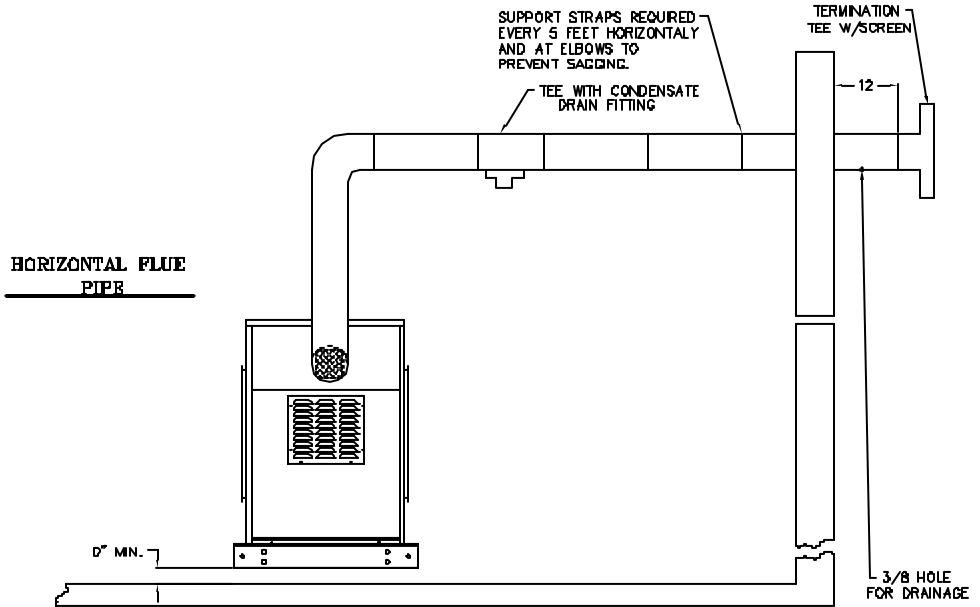
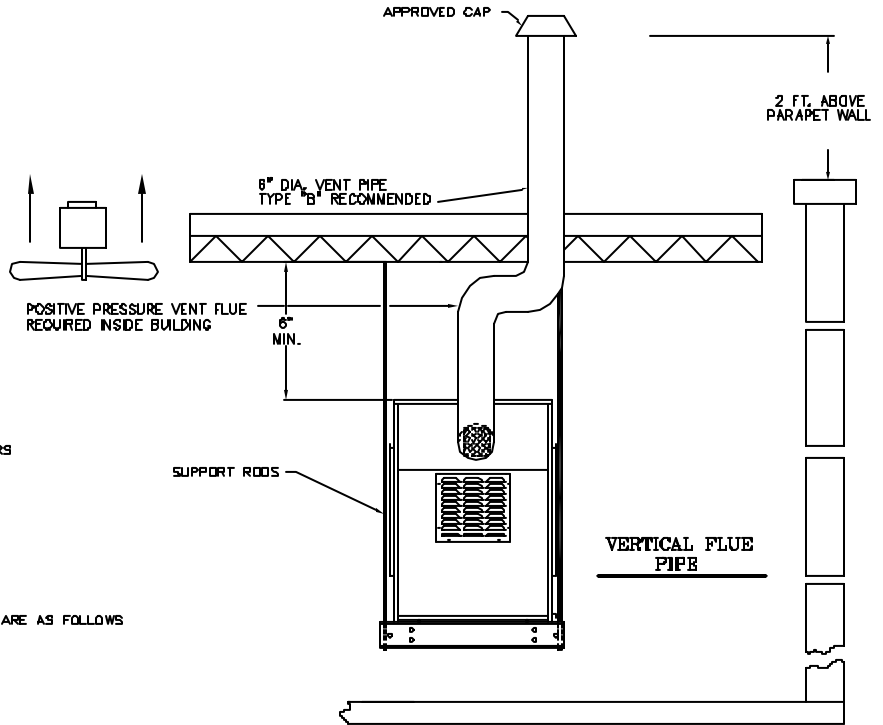

H. ILLUSTRATIONS:

Air Flow Through Furnace

With Bottom Discharge Blower

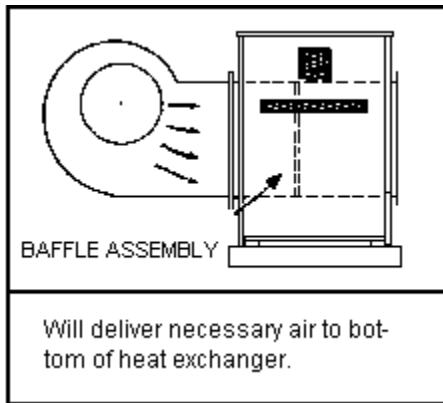

With Top Discharge Blower

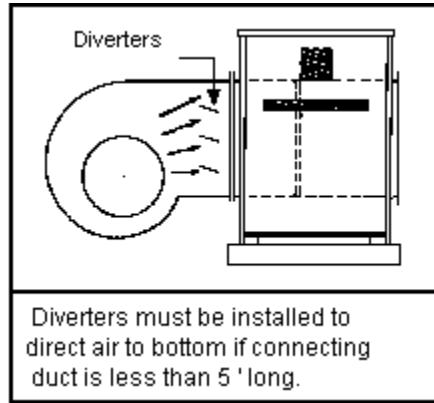

With Vertical Discharge Blower

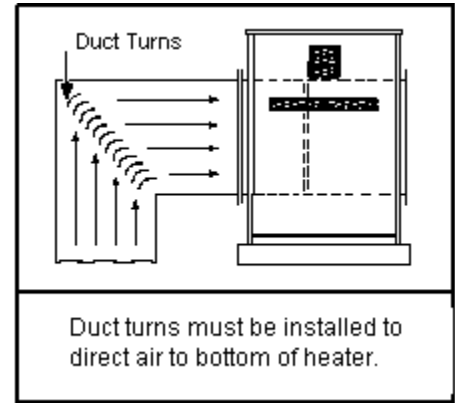

WARNING: Air must flow evenly through the entire heat exchanger. Otherwise the bottom or tubes on one side will overheat causing damage and voiding the warranty. Heat exchanger must be installed downstream of blower.

Dimensions (Outdoor Model)

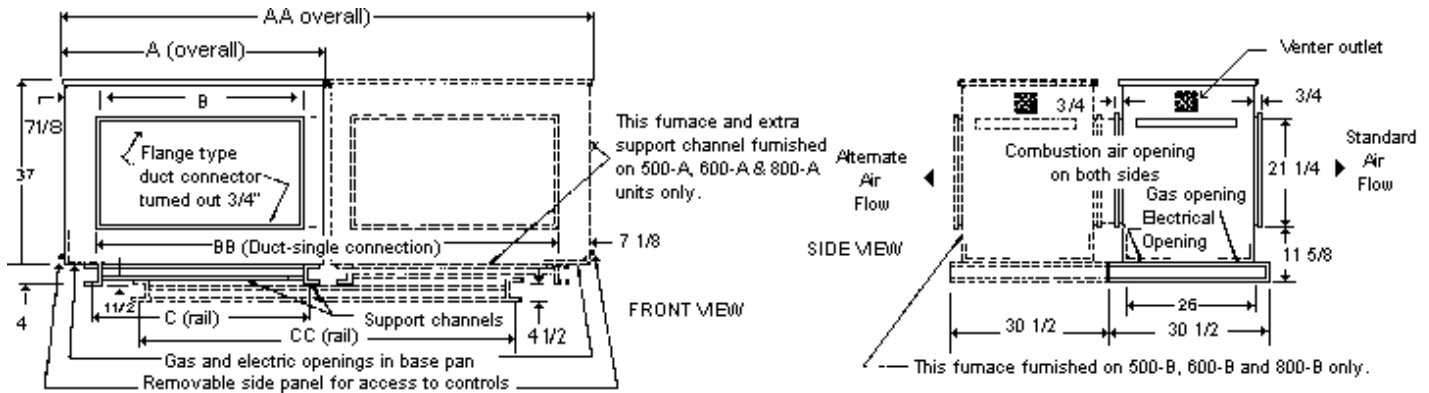

	HRDV MODEL NO.												
	100	125	160	210	250	300	400	500-A	500-B	600-A	600-B	800-A	800-B
A	30 5/8	30 5/8	41 3/8	41 3/8	41 3/8	52 1/16	65 1/2	-	52 1/16	-	52 1/16	-	65 1/2
AA	-	-	-	-	-	-	-	104 1/8	-	104 1/8	-	131	-
B	18	18	28 3/4	28 3/4	39 1/2	39 1/2	52 7/8	-	39 1/2	-	39 1/2	-	52 7/8
BB	-	-	-	-	-	-	-	87 3/4	-	87 3/4	-	114 5/8	-
C	21 7/8	21 7/8	32 5/8	32 5/8	43 3/8	43 3/8	56 7/8	-	43 3/8	-	43 3/8	-	56 7/8
CC	-	-	-	-	-	-	-	69 5/8	-	69 5/8	-	74 5/8	-

NOTE: All dimensions in inches. RD models 100-400 are A.G.A./C.G.A. design certified.

Dimensions (Indoor Models)

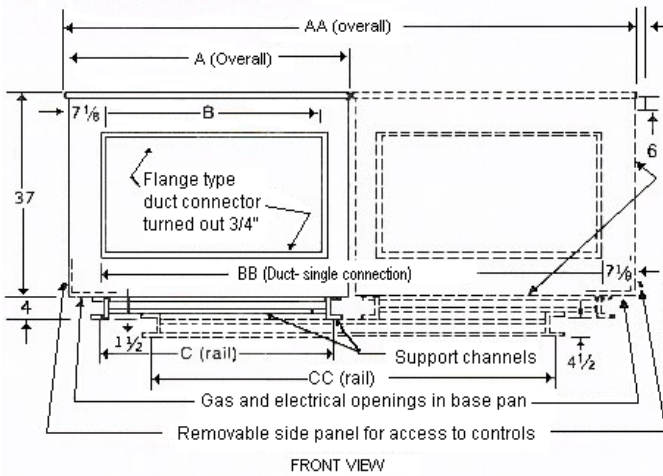

This furnace and extra support channel furnished on 500-A, 600-A & 800-A units only.

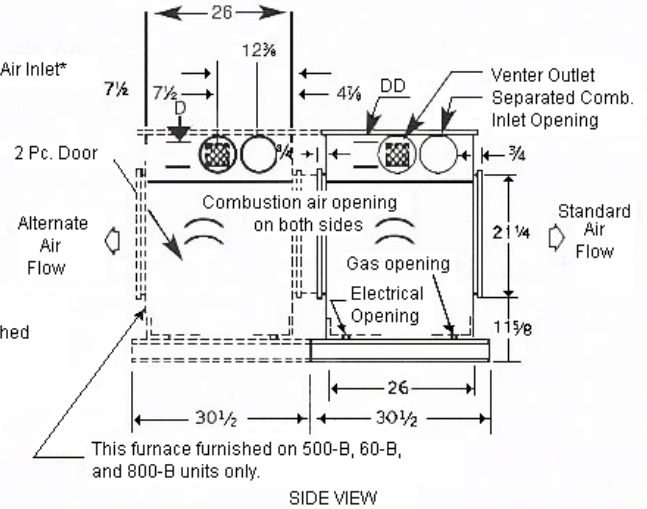

This furnace furnished on 500-B, 60-B, and 800-B units only.

ISHRDV, IHRDV, MODEL NO.													
	100	125	160	210	250	300	400	500-A	500-B	600-A	600-B	800-A	800-B
A	30 ⁷ / ₈	30 ⁵ / ₈	41 ³ / ₈	41 ³ / ₈	52 1/16	52 1/16	65 1/2	-	52 1/16	-	52 1/16	-	65 1/2
AA	-	-	-	-	-	-	-	104 ¹ / ₈	-	104 ¹ / ₈	-	131	-
B	18	18	28 ³ / ₄	28 ³ / ₄	39 1/2	39 1/2	52 ⁷ / ₈	-	39 1/2	-	39 1/2	-	52 ⁷ / ₈
BB	-	-	-	-	-	-	-	87 ³ / ₄	-	87 ³ / ₄	-	114 ⁵ / ₈	-
C	21 ⁷ / ₈	21 ⁷ / ₈	32 ⁵ / ₈	32 ⁵ / ₈	43 ³ / ₈	43 ³ / ₈	56 ⁷ / ₈	-	43 ³ / ₈	-	43 ³ / ₈	-	56 ⁷ / ₈
CC	-	-	-	-	-	-	-	-	-	69 ³ / ₈	-	74 ³ / ₈	-
D	6	6	6	6	6	6	6	(2) 6	(2) 6	(2) 6	(2) 6	(2) 6	(2) 6
DD	(2) 6	(2) 6	(2) 6	(2) 6	(2) 6	(2) 6	(2) 6	(4) 6	(4) 6	(4) 6	(4) 6	(4) 6	(4) 6

I. FACTORY SERVICE

Periodic service on any piece of mechanical equipment is necessary for efficient operation. If a service problem arises, Hastings HVAC, Inc. has a nationwide service organization available to provide professional assistance to help you with a solution to that problem. Two inbound Watts lines to the home offices enables you to consult with qualified factory service personnel. For needed parts, appliance data, or assistance on a service problem, contact the service department of Hastings HVAC, Inc. Also, when ordering replacement parts, be sure to specify the following:

1. Model and serial number of unit.
2. Type of gas or fuel.
3. Make of electric valve and voltage.

To contact Hastings HVAC, Inc. Service Department, outside of Nebraska call (800) 228-4243 or 228-4270 or write Hastings HVAC, Inc. 3606 Yost Avenue, Hastings, Nebraska 68901-1966. Telephone (402) 463-9821.



3606 Yost Avenue · Hastings Nebraska 68901-1966
 Phone (402) 463-9821 · Fax (402) 462-8006

www.hastingshvac.com

E-mail: sales@hastingshvac.com