

## **INSTALLATION AND OPERATION MANUAL**

### Evaporative Coolers

EC-40, -80, -120, -160, -220, -300, -400,  
-500, -600, and -750



### **NOTICE**

#### **Read These Instructions Before Installation**

Upon arrival, inspect the unit for shipping damage and completeness. If any part is missing or damaged, notify the carrier immediately. Always refer to the unit's serial and model numbers located on the specification plate when making an inquire regarding maintenance and parts. To insure unit integrity, use only Factory Authorized Replacement Parts.

# CONTENTS

Precautions .....	Page 2
Specifications .....	Page 3
Unit Installation .....	
1. Evaporative Cooler .....	Page 4
2. Wiring .....	Page 4
3. Water connections .....	Page 4
Operation	
1. Standard Unit .....	Page 5
2. Unit with automatic Drain Kit .....	Page 5
3. Unit with Automatic Drain Kit and Freeze Protection .....	Page 5
Service and Parts .....	Pages 6 and 7
Trouble Shooting .....	Page 8

## WARNING

This equipment was designed and manufactured with safe operation as a priority. However, the very nature of any equipment having water and electrical connections presents hazards to personnel which cannot be completely safeguarded against.

## PRECAUTIONS

1. Read these instructions before installation and operation; save for future reference. This manual contains necessary information for safe operation and maintenance of the unit.
2. **Shut off** main power and lock it in the **off** position when making repairs or replacements of components.
3. Use **extreme caution** when making voltage tests with “live” circuits – follow the established safety procedures.
4. Electrical repairs should be performed by trained, qualified personnel only. (Failure to follow safe electrical procedures can result in series injury – or *death*.)
5. **Do not** attempt to operate unit by jumping, or otherwise bypassing, any circuit.
6. Keep evaporator reservoir clean. **Do not** allow fine sediments or scale to accumulate in reservoir, on filter media, or on other components.
7. **Do not** exceed water pressures recommended in this manual.

# SPECIFICATIONS

Model (EC)	40	80	120	160	220	300	400	500	600	750
Dry Weight	110	176	225	271	310	373	634	726	845	1067
Operation Weight**	335	560	650	825	880	1135	1680	1930	2085	2635
Pump Cap/GPH req.*	270	360	540	720	720	810	540+	630+	630+	630+
Cap/GPH @ Lift*	387	1135	1135	1135	1135	1100	1080	1080	1060	1060
Pump Lift/ft.	3	4	4	4	4	5	6	6	7	7

\* These figures do not include the 3 to 6 percent bleed-off rate required to reduce scaling for standard unit.

\*\*Unit in operation, media fully saturated.

+ Per pump

EC = Evaporative cooler

## WATER CONNECTIONS ALL UNITS

1-1/2 FPT Overflow	¾ FPT Drain
½ MPT Bleed-off	½ FPT Float Valve

## ELECTRICAL SPECIFICATION

Model (EC)	40	80	120	160	220	300	400	500	600	750	
Pump Motor Model	CP 1000	5 MSP					(2) 5 MSP				
HP	1/50	1/6					1/6				
Amperage	1.1 A	5.0 A					5.0 A				
Voltage	115 V										

EC = Evaporative Cooler

## APPROXIMATE BLEED-OFF FLOW RATE

Model	EC-40 -80	EC-120 -160	EC-220 -300	EC-400 -750
Per Minute	½ to 1 qt.	1 to 2 qt.	2 to 3 qt.	2 (2-3 qt.)

## CONSTRUCTION AND MEDIA SPECIFICATION

	Celdek	Glasdek
Maximum Water Temperature	130°F	165°F
Maximum Air Temperature	300°F	300°F
pH Range	6-9	6-9
Cabinet	Aluminized Steel and Painted	
Evaporator Reservoir	Stainless Steel	

# INSTALLATION INSTRUCTIONS

1. When installing the evaporative cooler, special consideration should be given to the physical positioning of the unit, electrical power supply, the proper water supply, and the structural members to support the cooler at the operating weights. It is recommended that supports be placed within every four feet to distribute the weight evenly. Be sure the supports are level.
2. After the unit is properly located, electrical connection may be made. If the Evaporative Cooler has been purchased separately, wiring from a 115 volt supply may be connected to the junction box supplied with the unit. Refer to the wiring schematic supplied in owner's packet or, page 5 of typical wiring schematics, and to drawings for standard unit, units with automatic drain kit, or units with automatic drain kit and freeze protection.

When the evaporator cooler is purchased with a system exhaust blower and filter, most connections may have been made already. Refer to schematic with owner's packets for any additional wiring to be done.

**CAUTION:** The electrical wiring *must comply* with all applicable local state, or provincial and national ordinances and codes.

3. Water connections (refer to "Specifications") should, and must follow, local codes and ordinances. Connections are provided on each unit with standard pipe thread sizes. Refer to page 5 for your system. For units with automatic drain kit and freeze protection, the minimum pressure should be 10 PSI so valves will operate properly; for other models, 10 PSI or less.
4. Set the float valve (FV) to allow fresh water to enter reservoir to a depth of 2-1/2" for models EC-40 through EC-750. By loosening the thumb screw, located on the float valve assembly, and setting the float until the valve shut off is at the designed depth, no other adjustment need be made. Do not forget to tighten the thumb screw securely.
5. You may now start your unit. Watch for the first few times that the media gets completely saturated and that all phases of operations (See "Operations") are working properly. If necessary adjust the pump discharge gate valve to avoid dry areas on the media. Water should be visible trickling down the flutes of the media. Watch also for excess foaming (See "Trouble Shooting") of the water and media.

After a day of operation, you will notice the water to be a shade of green. The media is the cause, and the reservoir should be drained and refilled a couple of times to correct this.

6. Now proceed to the "Operation" part of this manual and read about the unit that you have purchased.

## OPERATION

Refer to the schematic piping and wiring while going through the start-up procedure for the particular system you have purchased.

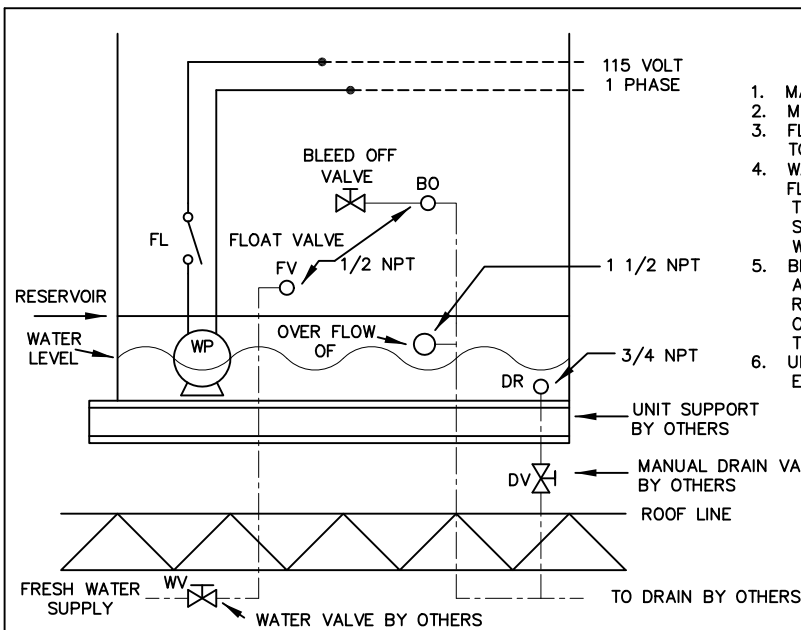

### STANDARD UNIT

1. MANUAL SHUT OFF VALVE (WV) IS OPENED.
2. MANUAL DRAIN VALVE (DV) IS CLOSED.
3. FLOAT VALVE (FV) ALLOWS FRESH WATER TO ENTER RESERVOIR.
4. WATER PUMP (WP) WILL START AS SOON AS FLOAT SWITCH (FL) CLOSSES. IF WATER IS TO LOW PUMP WON'T RUN. WATER PUMP (WP) SHOULD BE WIRED SO THAT PUMP CANNOT RUN WITHOUT BLOWER MOTOR IN OPERATION.
5. BLEED-OFF (BO) TO PREVENT SCALE FORMATION, A BLEED-OFF AT THE RATE OF 3-6% IS REQUIRED. THE EXACT AMOUNT WILL DEPEND ON THE pH AND HARDNESS OF THE WATER, AND THE INTENSITY OF EVAPORATION.
6. UNIT CAN BE USED WITH BLOWER ON AND EVAPORATIVE COOLER PUMP OFF.

----- FIELD WIRING  
 - · - · - · FIELD PIPING

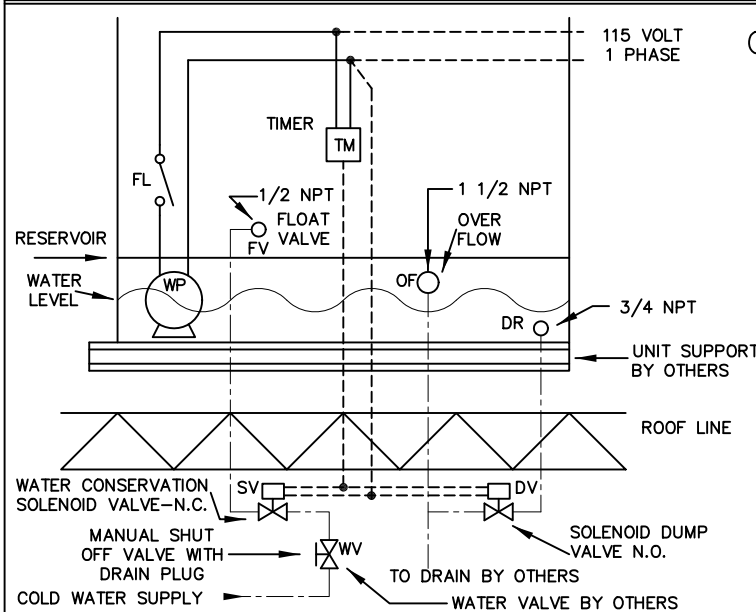

### OPTIONAL SOLENOID & TIMED DRAIN VALVE KIT

1. MANUAL SHUT OFF VALVE (WV) IS OPENED.
2. WHEN EVAPORATIVE COOLER IS ACTIVATED IT OPENS WATER CONSERVATION SOLENOID VALVE (SV), CLOSES N.O. DUMP VALVE (DV), WATER PUMP (WP) WILL START AS SOON AS FLOAT SWITCH (FL) CLOSSES. WATER PUMP (WP) SHOULD BE WIRED SO THAT PUMP CANNOT RUN WITHOUT BLOWER MOTOR IN OPERATION.
3. FLOAT VALVE (FV) ALLOWS FRESH WATER TO ENTER RESERVOIR.
4. TIMER (TM) BREAKS CIRCUIT TO DUMP VALVE (DV) N.O. FOR DAILY SEDIMENT REMOVAL. WATER CONSERVATION SOLENOID VALVE (SV) N.C. WILL NOT ALLOW SUPPLY WATER TO FLOAT VALVE (FV) DURING CYCLE. TIMER IS SET FOR 1 1/2 HOURS MINIMUM FOR DRAINING RESERVOIR.
5. UNIT CAN BE USED WITH BLOWER ON AND EVAPORATIVE COOLER PUMP OFF.

----- FIELD WIRING  
 - · - · - · FIELD PIPING

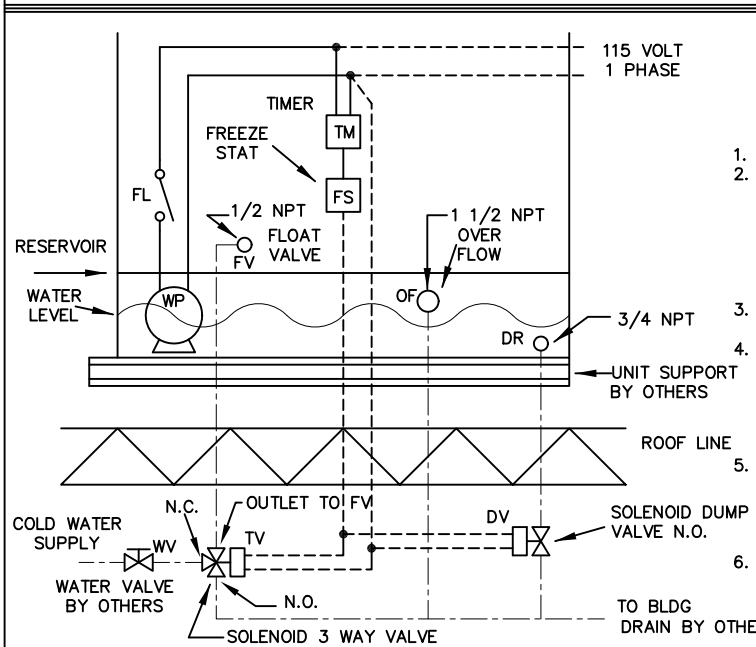

### OPTIONAL SOLENOID TIMED DRAIN VALVE KIT WITH FREEZE PROTECTION

1. MANUAL SHUT OFF VALVE (WV) IS OPENED.
2. WHEN EVAPORATIVE COOLER IS ACTIVATED IT CLOSES DUMP VALVE (DV), 3 WAY VALVE (TV) OPENS AND ALLOWS FRESH WATER TO FLOAT VALVE. WATER PUMP (WP) WILL START AS SOON AS FLOAT SWITCH (FL) CLOSSES. WATER PUMP (WP) SHOULD BE WIRED SO THAT PUMP CANNOT RUN WITHOUT BLOWER MOTOR IN OPERATION.
3. FLOAT VALVE (FV) ALLOWS FRESH WATER TO ENTER RESERVOIR.
4. TIMER (TM) BREAKS CIRCUIT TO DUMP VALVE (DV) N.O. FOR DAILY SEDIMENT REMOVAL. 3 WAY VALVE (TV) WILL NOT ALLOW SUPPLY WATER TO FLOAT VALVE (FV) DURING CYCLE. TIMER IS SET FOR 1 1/2 HOUR MINIMUM FOR DRAINING RESERVOIR.
5. FREEZE STAT (FZ) PROVIDES FREEZE PROTECTION BY AUTOMATICALLY DRAINING RESERVOIR THRU DUMP VALVE (DV), AND DRAINING COLD WATER SUPPLY FROM FLOAT VALVE (FV) THRU N.O. PARTS OF 3 WAY VALVE (TV).
6. UNIT CAN BE USED WITH BLOWER ON AND EVAPORATIVE COOLER PUMP OFF.

----- FIELD WIRING  
 - · - · - · FIELD PIPING 94-000-444-01

CK'D BY	DATE	CHG'D BY	DATE	REV LETTER	REVISION

**Hastings**  
 "HVAC", INC.

DRN. L.J.M.  
 DATE 7/14/87

SCHEMATIC WIRING DIAGRAM  
 EVAPORATIVE COOLER

PART NUMBER E536 (S08)  
 94-000-444-01

SEE LEGEND NOTE NUMBERS  
 AND GENERAL NOTES.

# SERVICE AND PARTS

Evaporative cooler media may be removed from the rear for cleaning or replacement, as required, by removing the upper rear panel. Use only standard garden hose variety, with minimal water pressure, to avoid damaging the filter media when cleaning. It would be advisable to replace evaporative cooler media every five years on units that are subject to contaminated atmospheres, or where water has a high mineral content.

Installation of evaporative media requires the 45 deg. angle flutes to slope down toward the air entering the pad. Use care in handling the pad to avoid damage.

## MEDIA INSTALLATION DETAIL

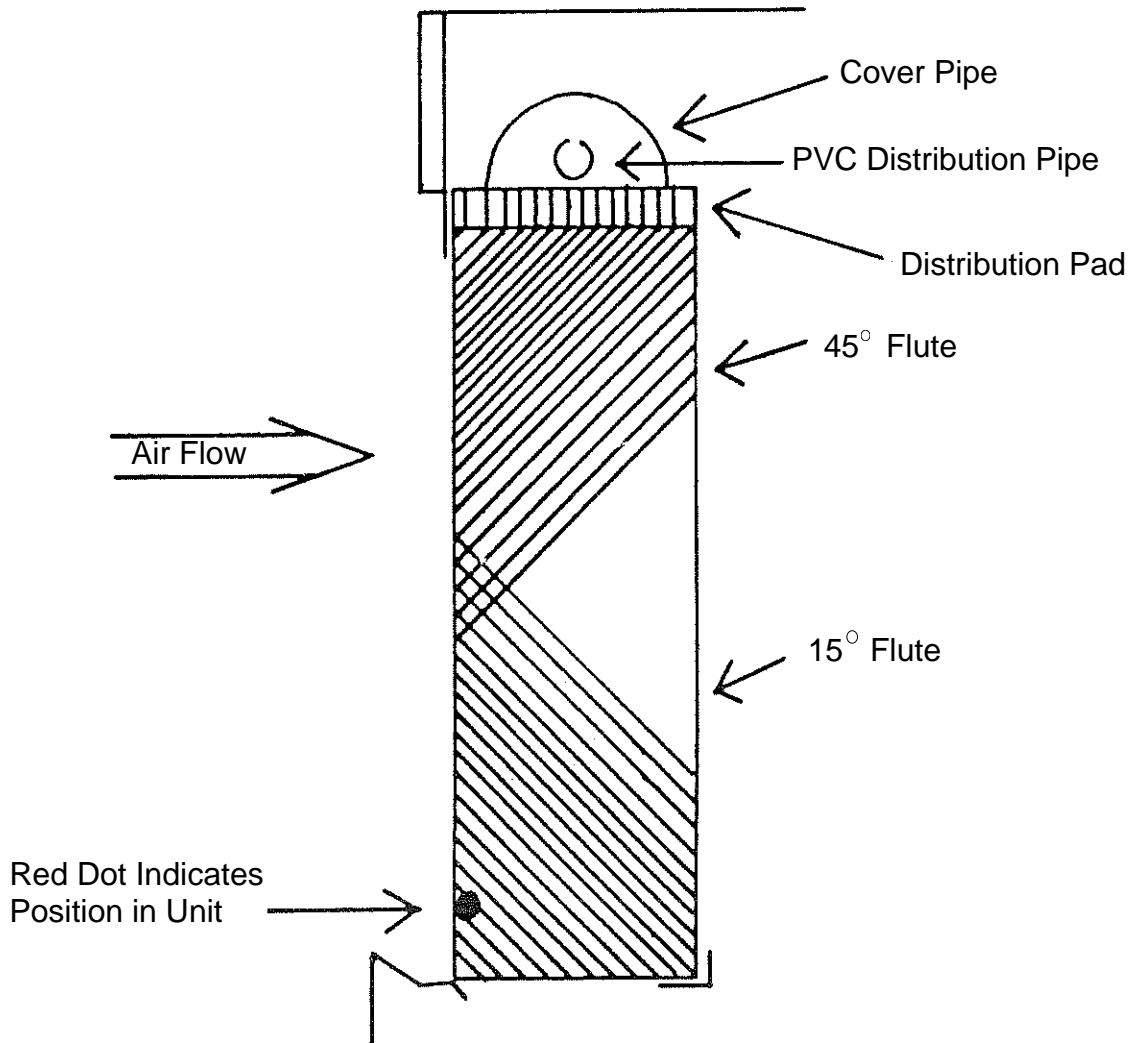

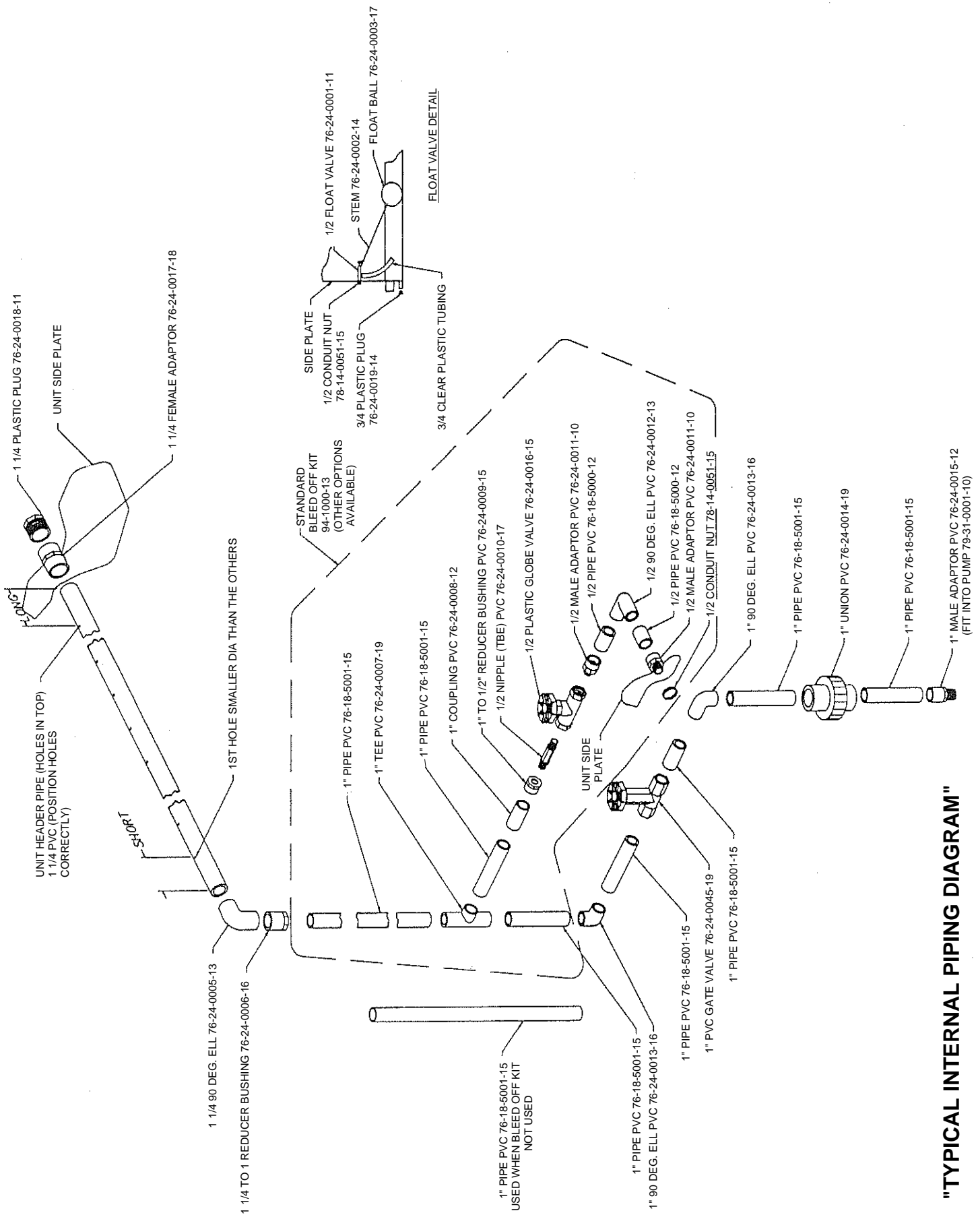

**"TYPICAL INTERNAL PIPING DIAGRAM"**

# TROUBLE SHOOTING GUIDE

PROBLEM	CHECK-OUT PROCEDURE AND CORRECTION
<b>Green Water</b> .....	<ol style="list-style-type: none"><li>1. Usually occurs the first few days of operation; media is being rinsed. Drain reservoir and refill with fresh water. After a couple of operations, green should disappear. The 3 to 6 percent bleed-off, for standard units, will maintain your clear water also.</li><li>2. If unit has been in service for a while, algae can grow on the media. It will not cause deterioration or rot, but may clog the passages and inhibit the air flow. A commercial algaecide will control the growth when caught in the early stages.</li></ol>
<b>Foaming Occurs</b> .....	<ol style="list-style-type: none"><li>1. Some foaming is natural if maintained in the reservoir. If foaming of the media occurs after a couple of days of operation, a defoamer should be added. The exact amount will depend on the severity. After one application, you will be able to judge how much additional defoamer to use (see instructions on bottle).</li></ol>
<b>Scaling Occurs</b> .....	<ol style="list-style-type: none"><li>1. Be sure you have a 3 to 6 percent bleed-off rate (See "Bleed Off Flow Rates.") for unit size. If the frost-like scale does appear, increase water flow by adjusting pump discharge gate valve until it disappears. The exact amount will depend upon the pH and hardness of the water and the intensity of evaporation. Clean and flush distribution header on a regular basis.</li></ol>
<b>Water depositing into Transition and Reservoir Not Draining</b> .....	<ol style="list-style-type: none"><li>1. Reservoir float valve (FV) improperly adjusted (See "Installation Instructions," note 4.)</li><li>2. Float valve bad, not shutting off. Replace.</li><li>3. Check overflow and drain valves for blockage. On models with timed drain valve, check time clock setting or solenoid valve (DV). Replace if bad.</li><li>4. After initial start-up, look for foaming of the media. If the blower is pulling foam bubbles off the media into transition, a static pressure or CFM problem is eminent. (Contact your service or unit representative.)</li></ol>
<b>Reservoir Dry</b> .....	<ol style="list-style-type: none"><li>1. Check the manual shut-off valve. Is it open?</li><li>2. Is the float valve opening? If not, then readjust float level or replace valve.</li><li>3. Units with conservation water solenoid should be checked. Replace if bad.</li></ol>
<b>Water Out the Backside of Evaporative Cooler</b> .....	<ol style="list-style-type: none"><li>1. Water pump is running without the blower running.</li><li>2. Damaged media. Replace.</li><li>3. If these problems, contact your service or unit representatives:<ol style="list-style-type: none"><li>A. Lack of CFM.</li><li>B. Improper static pressure.</li></ol></li></ol>

