

Installation and Service Manual INDOOR/OUTDOOR HEATING, HEATING/COOLING SYSTEMS AND INDIVIDUAL DUCT FURNACES



Notice

Read These Instructions Before Installation

Inspect unit on arrival for any shipping damage. This unit has been test fired for at least 15 minutes to prove out all phases of operation. If any part is missing or damaged, notify the carrier at once.



 **WARNING:**

FIRE OR EXPLOSION HAZARD

Failure to follow safety warnings exactly could result in serious injury, death or property damage.

Be sure to read and understand the installation, operation and service instructions in this manual.

Improper installation, adjustment, alteration, service or maintenance can cause serious injury, death or property damage

- Do not store or use gasoline or other flammable vapors and liquids in the vicinity of this or any other appliance.

- **WHAT TO DO IF YOU SMELL GAS**
 - Do not try to light any appliance.
 - Do not touch any electrical switch; do not use any phone in your building.
 - Leave the building immediately.
 - Immediately call your gas supplier from a phone remote from the building. Follow the gas supplier's instructions.
 - If you cannot reach your gas supplier, call the fire department.

- Installation and service must be performed by a qualified installer, service agency or the gas supplier.

 **AVERTISSEMENT:**

RISQUE D'INCENDIE OU D'EXPLOSION

Le non respect des mises en garde pourrait entrainer des blessures graves, la mort ou des pertes matérielles.

Prendre soin de lire et de comprendre les instructions d'installation, de fonctionnement et d'entretien contenues dans ce guide.

Une installation, un réglage, une modification, une réparation ou un entretien inapproprié peut entrainer des blessures graves, la mort ou des pertes matérielles.

- Ne pas entreposer ni utiliser d'essence ou autre vapeurs ou liquides inflammables à proximité de cet appareil ou de tout autre appareil.

- **QUE FAIRE SI VOUS SENTEZ UNE ODEUR DE GAZ**
 - Ne tentez pas d'allumer un appareil.
 - Ne touchez pas à un interrupteur; n'utilisez pas de téléphone dans l'édifice où vous vous trouvez.
 - Sortez de l'édifice immédiatement.
 - Appelez immédiatement le fournisseur de gaz à partir d'un téléphone à l'extérieur de l'édifice. Suivez les instructions du fournisseur de gaz.
 - Si vous ne pouvez joindre le fournisseur de gaz, appelez les pompiers.

- L'installation et les réparations doivent être confiées à un installateur qualifié ou au fournisseur de gaz.

TABLE OF CONTENTS

	Page
HRDV Dimension.....	1
Shipping.....	2
Hoisting Unit.....	2
Installation.....	2-4
Location.....	4-5
Electrical.....	5
Venting.....	5-9
Gas Supply Piping.....	9-10
Operation of Electronic Modulating Valve.....	11-12
Maintenance.....	12-17

Model and Serial Number can be found on equipment spec. plate located on blower cabinet side.

Model # _____

Serial # _____

Date of Purchase _____

Purchased from _____

Dimensions (Outdoor Model)

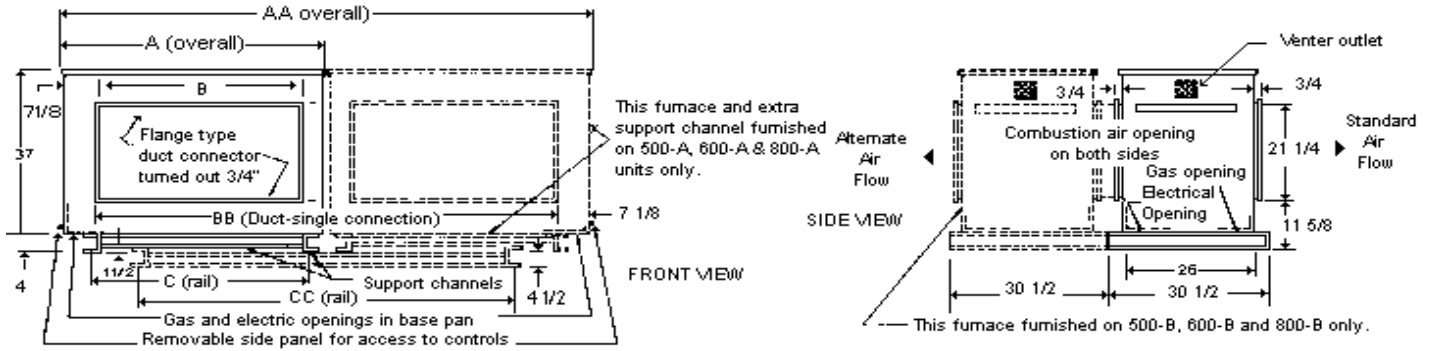

OUTDOOR MODEL NO.

	100	125	160	210	250	300	400	500-A	500-B	600-A	600-B	800-A	800-B
A	30 5/8	30 5/8	41 3/8	41 3/8	41 3/8	52 1/16	65 1/2	-	52 1/16	-	52 1/16	-	65 1/2
AA	-	-	-	-	-	-	-	104 1/8	-	104 1/8	-	131	-
B	18	18	28 3/4	28 3/4	39 1/2	39 1/2	52 7/8	-	39 1/2	-	39 1/2	-	52 7/8
BB	-	-	-	-	-	-	-	87 3/4	-	87 3/4	-	114 5/8	-
C	21 7/8	21 7/8	32 5/8	32 5/8	43 3/8	43 3/8	56 7/8	-	43 3/8	-	43 3/8	-	56 7/8
CC	-	-	-	-	-	-	-	69 5/8	-	69 5/8	-	74 5/8	-

NOTE: All dimensions in inches. All models 100-400 are E.T.L. design certified.
Check installation manual for recommended clearances.

Dimensions (Indoor Models)

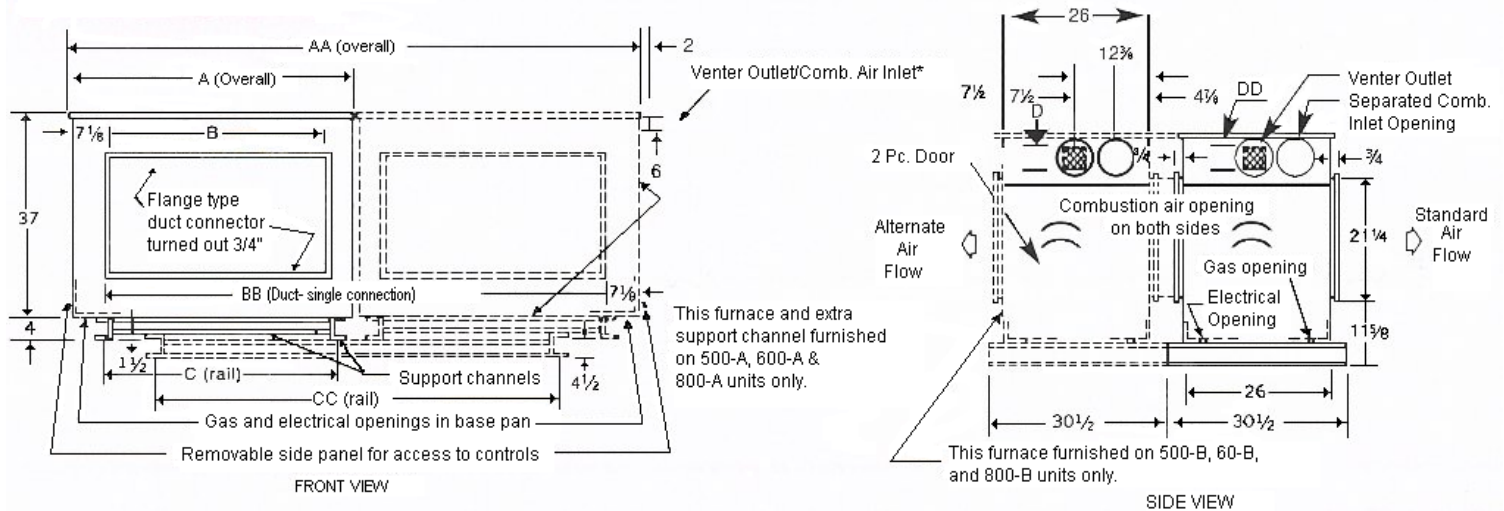

INDOOR MODEL NO.

	100	125	160	210	250	300	400	500-A	500-B	600-A	600-B	800-A	800-B
A	30 5/8	30 5/8	41 3/8	41 3/8	52 1/16	52 1/16	65 1/2	-	52 1/16	-	52 1/16	-	65 1/2
AA	-	-	-	-	-	-	-	104 1/8	-	104 1/8	-	131	-
B	18	18	28 3/4	28 3/4	39 1/2	39 1/2	52 7/8	-	39 1/2	-	39 1/2	-	52 7/8
BB	-	-	-	-	-	-	-	87 3/4	-	87 3/4	-	114 5/8	-
C	21 7/8	21 7/8	32 5/8	32 5/8	43 3/8	43 3/8	56 7/8	-	43 3/8	-	43 3/8	-	56 7/8
CC	-	-	-	-	-	-	-	-	-	69 5/8	-	74 5/8	-
D	6	6	6	6	6	6	6	(2) 6	(2) 6	(2) 6	(2) 6	(2) 6	(2) 6
DD	(2) 6	(2) 6	(2) 6	(2) 6	(2) 6	(2) 6	(2) 6	(4) 6	(4) 6	(4) 6	(4) 6	(4) 6	(4) 6

NOTE: All dimensions in inches. All models 100-400 are E.T.L. design certified.
Check installation manual for recommended clearances.

*Indoor Separated Combustion model will have (1) venter outlet and (1) combustion air inlet per duct furnace.

SHIPPING

1. The unit is shipped by either common carrier or flat bed trailer. Consult with the factory on number of sections per load.
2. Units supplied with four duct furnaces will have downstream duct furnaces shipped separate and will require field assembly.
3. The remote control panel, when provided, is shipped unmounted.

HOISTING UNIT

1. The weight of the systems are available by contacting Hastings HVAC, Inc.
2. At least four (4) lines (minimum) and suitable spreaders should be used to lift the unit with slings placed at equal distances under the 4" high base frame, or flat platform lift with proper lifting weight ability should be used. Unit must be slinged properly with multiple lifting points to prevent the unit from sagging – DO NOT SLING UNDER PLENUMS (OUTDOOR ONLY) FOR LIFTING.
3. On units with either inlet or discharge plenums, or both, suitable slings must be provided for support beneath the unit's 4" high base frame. A minimum of four support slings are required. Additional sling supports may be needed for long pieces of equipment.

WARNING – The mechanical or structural engineer should be contacted before moving unit across the roof deck.

INSTALLATION

1. The unit may be installed on a field fabricated mounting frame or support, a factory roof curb mounting frame or a slab. The following items are important in this regard:
 - A. Be sure that roof joist or support will not interfere with discharge and return air ducts.
 - B. Be sure frame or support is square, level and not twisted.
 - C. Field fabricated frame, support, or slab must be high enough to prevent any form of moisture from entering unit.
 - D. All joints on frame must be sealed with caulking compound.
 - E. Field fabricated curb should be insulated with at least 1 ½" thick rigid type insulation.
 - F. The roof curb should be counterflashed and sealed before unit is installed.
 - G. Standard flashing and mopping procedures are recommended for curb openings and gas and electrical roof penetrations.
 - H. Deck curb available to provide covered island under complete unit with openings for supply and return air.
 - I. Duct furnace must be installed on the positive side of air supply blower. The blower must provide air through-put within range specified on the appliance spec plate.
2. The discharge and return air duct (if required) should be correctly sized for securing to factory installed plenums, when provided, or to unit. Duct connection(s) exposed to the weather must be watertight. A weather tight seal must be provided where duct(s) comes through the roof.
3. A duct furnace shall be installed with an inlet duct which will provide air distribution equivalent to a straight run of duct having the same cross-sectional area as the inlet connection and not less than 2 equivalent diameters in length.
4. Installation of duct furnaces shall specify that the ducts connected to the duct furnace shall have removable access panels on both upstream and downstream sides of the duct furnace. These openings shall be accessible when the appliance is installed in service, and shall be of such size that smoke or reflected light may be observed inside the casing to indicate the presence of leaks in the heating element. The cover for the opening shall be attached in such a manner as to prevent leaks.

WARNING

INSTALLATION PRECAUTIONS:

NOTE: GUARANTEE OF THIS EQUIPMENT IS SUBJECT TO CONFORMANCE WITH THE FOLLOWING:

1. Heater Location Requirements:

- a. Outdoor units with poor venting, pilot outage, and other undesirable operating conditions may be caused by a negative pressure condition or high pressure zones created by walls or other obstructions. Therefore, the furnace must be located as far as possible from the source of such turbulence and at least six feet from the edge of the roof.
- b. Indoor units must NOT be operated in the presence of CHLORINATED SOLVENTS. Even slight traces of chlorine combined with products of combustion will cause serious damage.
- c. Indoor units must have adequate COMBUSTION AIR. If heaters are installed in a closed room, provide outside opening of one square inch per 1,000 BTU for combustion air alone.
- d. Indoor units must not operate in an area with a negative air pressure condition. Provide adequate MAKE-UP AIR.
- e. Indoor units installed where there is sawdust, lint, soot, dirt, etc., areas of high air contamination, must be cleaned FREQUENTLY or serious damage will result. Refer to section on CLEANING for recommended frequency.

2. WARNING: Installer/Service Technician must remove burner tray to inspect burner assemblies, to insure proper alignment. Prior to installing gas supply line to unit gas inlet, remove the "L" locking bracket and disconnect the electrical connections and slide the burner tray out of the heater. Once inspection is completed, replace the burner tray assembly and install the "L" locking bracket. **Failure to perform this inspection could result in fire, explosion, loss of warranty, or even death.**

3. a. Firing rate must NOT be increased above the BTU input shown on the specification plate.
b. Instructions shall state that the appliance shall be adjusted to the manifold pressure specified on the manufacturer's rating plate.
4. For U.S. installations at elevations above 2,000 feet (610 M), the appliance shall be derated 4 percent for each 1,000 feet (305 M) of elevation above sea level. For Canadian installations, appliances are certified for altitudes of 0 to 2,000 feet (0-610 M) and 2,000 to 4,500 feet (610-1,370 M). High altitude ratings may be obtained by a change in orifice size and/or manifold pressure. Contact the manufacturer or gas company before changing spud sizes or pressure regulator setting. Use ½ inch socket wrench to remove spuds. NOTE: L.P. GAS UNITS ARE EQUIPPED WITH SPECIAL TAPER REAMED SPUDS WHICH MUST NOT BE RESIZED IN THE FIELD.
5. Air starvation is a common cause of heat exchanger burn out. Air handling system design MUST POSITIVELY ASSURE adequate and evenly distributed air flow through the heat exchanger. See ILLUSTRATIONS on page 11.
6. The furnace must be installed downstream from or on the POSITIVE PRESSURE SIDE of the air circulating blower
7. Air flow through the furnace may be in either direction. However, on units with an air distribution baffle assembly, the air flow must enter the furnace from the baffle side. If entering air is desired from the opposite side, the baffle assembly must be relocated to that side of the heat exchanger. High SCFM models do not require this baffle assembly and are recognized by the suffix letter "H" in the furnace model number. (Example: IHRDV-400HME).
8. a. High SCFM model furnaces require heating air temperature rise be maintained at between 10° to 60° F. On units with the baffle assembly temperature rise must be maintained between 40° to 100° F. Units must not be adjusted to obtain temp. rise above these ranges.
b. Instructions accompanying duct furnaces shall state that the installation is to be adjusted to obtain an air through-put within the range specified on the appliance rating plate.
9. Filters, if used, must be cleaned or replaced as often as is necessary so as not to restrict air delivery.
10. Furnaces installed in areas of high air contamination may require FREQUENT cleaning. Refer to section on CLEANING for recommended frequency.
11. The (I) (IS) HRDV furnaces are design certified for operation with modulating or two-stage gas controls. When either modulating or two-stage controls are ordered, a thermostatic type fan control switch must NOT be used. With these gas controls, constant fan operation, simultaneous fan and gas valve operation, or a fan time delay relay must be employed.
12. If a fan control is not used, the blower must operate continuously or whenever the gas valve opens.

NOTE: AS AN ADDED PRECAUTION, INSTALL EITHER AN AIR PROVING SWITCH OR A SINGLE POLE, NORMALLY OPEN RELAY IN THE ELECTRIC GAS VALVE CIRCUIT. THE AIR PROVING SWITCH WOULD SENSE AIR CIRCULATION THROUGH THE SYSTEM. THE RELAY WOULD BE ENERGIZED BY THE LOAD SIDE OF THE BLOWER MOTOR STARTER. EITHER SWITCH WOULD THEN ACTIVATE THE GAS VALVE TO OPEN, BUT ONLY WHEN THE BLOWER WAS OPERATING.

13. The high limit control switch is a safety control that provides protection if furnace overheats due to blower failure, restricted air flow, or faulty controls. If unit overheats the limit switch breaks the circuit to the electric gas valve and closes gas supply. When the temperature of the heat exchanger drops to a safe degree, the limit switch automatically rests and permits the gas valve to open again. Cause of trouble must be corrected IMMEDIATELY to avoid serious damage to the furnace. The limit switch is a safety control, NOT AN OPERATING CONTROL.
14. Special precautions for furnaces used in conjunction with AIR COOLING and MAKE-UP AIR SYSTEMS:
 - a. Type 409 STAINLESS STEEL heat exchanges may be used in all applications, but is recommended for make-up air systems where inlet air temperature is ABOVE 40 ° F.
 - b. If furnace is used in either make-up air or air cooling applications, significant quantities of condensate may form.
15. Field installed ductwork on the unit discharge end must be secured to the flanges on the heat exchanger and not on unit front cabinet. Failure to properly install could cause fire, explosion, damage to equipment or even death.
16. Venting (I) (IS) indoor duct furnaces. Venting must be installed by a qualified installer in accordance with all local codes. In the absence of local codes, venting must be installed in accordance with the latest edition of the National Fuel Gas code, ANSI Z223.1/NFPA#70, Part 7, venting of equipment. In Canada, venting must be in accordance with the latest edition of the Natural Gas Installation Code CAN/CGA-B149.1; propane installation code CAN/CGA-BA49.2. A built-in power venter is provided – do not connect into any additional mechanical draft systems operating under a positive pressure. Improper installation can create a hazardous condition such as explosion, fire, carbon monoxide poisoning, resulting in property damage, person injury or death.

INSTALLATION:

• Regulations:

Installation of this appliance must conform to applicable federal, state, and local codes and regulations, and with guidelines established by C.G.A. (Canadian Gas Association), NFPA (National Fire Protection Association), N.E.C. (National Electrical Code), the National Board of Fire Underwriters and CAN/CGA B149. Listed are codes appearing in this text, the Associations, and their addresses where they may be obtained.

- | | |
|--|---|
| <ol style="list-style-type: none"> 1. Intertek Testing Services NA Inc. (E.T.L.)
Contact: Intertek Testing Services NA Inc.
165 Main Street
Cortland, New York 13045 3. Standard of National Board of Fire Underwriters
Contact: National Board of Fire Underwriters
85 John Street
New York, New York 10036 | <ol style="list-style-type: none"> 2. All NFPA codes, National Electrical Code
Contact: National Fire Protection Association, Inc.
Batterymarch Park
Quincy, Massachusetts 02269 5. Canadian Gas Association
Contact: Canadian Gas Association
178 Rexdale Boulevard
Etobicoke, Ontario, Canada M9W 1R3 |
|--|---|

LOCATION

NOTE: AMERICAN INSTALLATIONS MUST CONFORM WITH THE NATIONAL FUEL GAS CODE (AMERICAN NATIONAL STANDARD ANSI Z223.1/NFPA54 – “Latest Revisions”) AND ALL APPLICABLE GOVERNING BUILDING CODES. CANADIAN INSTALLATIONS MUST CONFIRM WITH CAN/CGA B149 – “Latest Revisions”.

THE INSTALLATION SHALL CONFORM WITH LOCAL BUILDING CODES, OR IN THE ABSENCE OF LOCAL COES, WITH THE NATIONAL FUEL GAS CODE, ANSI Z223.1/NFPA 54, OR THE NATURAL GAS AND PROPANE INSTALLATION CODE, CSA B149.1.

1. The duct furnace has been designed for INDOOR OR OUTDOOR INSTALLATIONS.
2. Refer to items 1, 2, 5, 6, 9, 10 12, 15, and 16 of INSTALLATION PRECAUTIONS.
3. REQUIRED MINIMUM CLEARANCES to combustible material are as follows:

CLEARANCES/INSTALLATION

Outdoor Models

The minimum clearances from combustible material are as follows:

- Control Side – Width of Unit
 - Opposite Control Side – 6 inches (18” recommended for servicing)
 - Top of Unit – Unobstructed
 - Discharge and Return Air Sides – 12 inches
 - Bottom – 0 inches
- For installation downstream from refrigeration systems.

CLEARANCES/INSTALLATION

Indoor Models

The minimum clearances from combustible material are as follows:

Control Side – Width of Unit

Opposite Control Side – 6 inches (18" recommended for servicing)

Top of Unit – 6 inches

Discharge and Return Air Sides – 12 inches

Bottom – 0 inches

For installation downstream from refrigeration systems.

* See section on ILLUSTRATIONS for dimensions of individual furnaces.

4. Install in airplane hangars in accordance with the current ANSI/NFPA 409 - "Latest Revisions", Standard on Aircraft Hangars, and in public garages in accordance with the current ANSI/NFPA BB - "Latest Revisions", Standards for Garages, and with CANI-B149 Codes. A clearance of 10 feet must be provided from the bottom of the heater to the top surface of wings or engine enclosures of the highest aircraft to be housed in the hangar and a minimum clearance of 8 feet from the door in other sections such as offices and shops connected with hangar and in public garages. Also, the heaters must be so located that they will be protected from damage by aircraft, cranes, scaffolding, etc., and must be accessible for servicing and adjustment. Standard ANSI/NFPA 88 A, B - "Latest revisions" specifies that the heater must be so located that the clearance to combustible materials conform with NFPA Nos. 52 and 54 and that such material must not attain a temperature over 160° by continued operation of the heater.
5. If two furnaces are to be used in a side by side application, they must be installed so that the ENDS OPPOSITE the control access doors ADJOIN.
6. A 4-inch frame is an integral part of the appliance and may be installed directly on the floor or roof or other combustible construction. For ease of service and safe operation, however, it is suggested that the furnace be located above the installation surface on a field fabricated base and should be high enough to prevent any form of moisture from entering the unit.
7. Be sure that the roof joists or other obstructions will not interfere with the discharge and return air ducts.
8. The discharge and return air ducts should be correctly sized for securing to the furnace and all connections exposed to the weather must be moisture tight. A high temperature caulking (250°F) or sheet metal flashing may be used for this purpose. A weathertight seal must be provided where ducts enter through the roof. Field installed ductwork on the unit discharge end must be secured to the flanges on the heat exchanger and not on unit front cabinet. **Failure to properly install could cause fire, explosion, damage to equipment or even death.**
9. Provide tight fitting inspection panels in duct work both upstream and downstream close to the furnace. These panels must be large enough so that the heat exchanger can be easily inspected.
10. Outdoor units must be installed from any building exhaust fan at a minimum distance of 10 feet.
11. For installations where heater is installed in a garage, it shall be installed with a minimum clearance above the floor of 18 in. (457 mm).

ELECTRICAL

1. Unit must be electrically grounded and all wiring must be done in accordance with applicable local codes and the National Electrical Code, ANSI/NFPA 70, and/or the CSA C22.1 Canadian Electrical code, if an external electrical source is utilized.
2. In order to determine the size of the power supply lines, check the electrical specification plate located on the unit for ampere requirements.
3. On units not ordered with a disconnect switch, it is recommended that a weatherproof disconnect switch be mounted on or near the unit.
4. Connect power supply lines from main disconnect switch to unit disconnect switch.
5. Install thermostat or remote control station if supplied according to wiring diagram.
6. Thermostats and remote control stations must be installed in a suitably protected and secure location to preclude tampering and damage. Thermostats must not be exposed to physical shocks or jarring either before or after installation.

VENTING

1. The Indoor model furnace is equipped with a power venter and is complete as received.
2. No further venting of unit is required for outdoor installation.
3. Indoor units (I) or (IS) are equipped with a blocked vent switch (VS-1) to shut off the main burners in the event the vents are blocked sufficiently to prevent proper operation of the burners. The blocked vent switch is factory set and should not be adjusted. If the blocked vent switch is determined to be the reason for the burners to shut off, consult factory service agent for instructions before attempting to place furnace back into operation.

4. Venting is required on all indoor installations (IS), and (IH) units – See drawings “S-136” and “S-137” for recommended arrangements.
 - a. Positive pressure flue vent is recommended for installations inside building. Provide for the (IS) and (IH) Series. For the requirement of positive pressure flue vent, review local codes.
 - b. Pitch vent pipe up toward outlet, 1/4” per foot for condensate drainage.
 - c. Type “B” gas vent is recommended for flue venting above roof lines or external wall penetrations.
 - d. Straight vertical runs out through the roof are preferred. Vertical stack must be a minimum of five feet high.
 - e. Vertical flue stacks shall be terminated with an approved cap.
 - f. The maximum horizontal vent pipe length for these heaters is shown in table II. A total equivalent horizontal vent pipe length can be calculated using equivalent straight pipe lengths for tees and elbows reducing the maximum horizontal vent pipe length by six feet for each sweep elbow, two and one half feet for termination tee, and ten feet for each short radius elbow.
 - g. Termination vents with screens require periodic cleaning to prevent the loss of proper venting, which can trip the blocked vent switch.
 - h. A gradually tapered vent pipe transition is required for (I) and (IS) units when using 4 inch vent pipe.
 - i. When possible, locate horizontal vent hoods that do not face the direction of prevailing winds to diminish the possibility of back draft situations.
 - j. For U.S.A. standards vent systems must conform to the latest edition of the National Fuel Gas Code (NFPA#54) and the latest edition of NFPA #211, or as follows:
 - Not less than 7 feet above grade when located adjacent to public walk ways.
 - At least 3 feet above any forced air inlet located within 10 feet.
 - At least 4 feet below, 4 feet horizontally from or 1 foot above any door, window or gravity air inlet into any building.
 - At least 1 foot above grade, or at least 1 foot above the normally expected snow accumulation level.
 - Directed such as to not jeopardize people.
 - At least 4 feet from electric meters, gas meters, regulators and relief equipment.
 - Sealing or shielding of exposed surfaces with a corrosion resistant material may be required to prevent staining or deterioration of building materials, and
 - Not less than 2 feet from an adjacent building.
 - k. In Canada vent systems must conform to the latest edition of the Natural gas and Propane Installation Code (CAN/CGA-B149.1 or CAN/CGA-B149.2), or as follows:
 - A venting system shall not terminate underneath a veranda, porch, or deck, or above a paved sidewalk or a paved driveway that is located between two buildings, and that serves both buildings.
 - The exit terminals of mechanical draft systems shall not be less than 2.14m above grade when located adjacent to a paved sidewalk or driveway.
 - A venting system shall not direct flue gases towards brickwork, siding, or other construction, in such a manner that may cause damage from heat or condensate from the flue gases.
 - A vent system shall not direct flue gases so as to jeopardize people, overheat combustible structures, or enter buildings.
 - A venting system shall not terminate within 1.8m of the following:
 - A window, door or mechanical air supply inlet of any building, including soffit openings.
 - A gas service regulator vent outlet.
 - A combustion air inlet.
 - A property line.
 - A direction facing combustible materials or openings of surrounding buildings
 - A venting system shall not terminate within 1m of the following:
 - Above a gas meter/regulator assembly within 1m horizontally of the vertical centerline of the regulator.
 - An oil tank or an oil tankfill inlet.
 - The inside corner of an L-shaped structure.
 - A venting system shall not terminate within .3m of the following:
 - Above grade level or any surface that may support snow, ice, or debris.
 - l. Distance from adjacent public walkways, adjacent buildings, openable windows and building openings, shall conform with local codes, or in the absence of local codes, with the National Fuel Gas Code, ANSI Z223.1/NFPA 54, or the Natural Gas and Propane Installation Code, CSA B149.1;
 - m. Information that local codes may supersede any of the above provisions.

BLOWER

1. Remove any tie downs if blower is internally isolated (painted yellow)
2. Lubricate bearings prior to unit start-up. Refer to ADDITIONAL MAINTENANCE PROCEDURES page 13, item 6.

"VENTING"

INDOOR DUCT HEATER WITH SEPERATED COMBUSTION OR INDOOR HEATING-HEATING/COOLING SYSTEMS

INSTALLATION

VERTICAL/HORIZONTAL FLUE PIPE

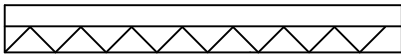

IF EXHAUST FAN IS USED DURING THE HEATING SEASON
PROVIDE ADEQUATE "MAKE-UP" AIR AND COMBUSTION
AIR.

INSTALL IN AIRPLANE HANGARS IN ACCORDANCE WITH
CURRENT NFPA NO. 409 STANDARD ON AIRCRAFT HANGARS
AND IN PUBLIC GARAGES IN ACCORDANCE WITH CURRENT
NFPA NO. 88 STANDARD FOR GARAGES. SEE PAGE 4 FOR
DETAILS.

CLEARANCES/INSTALLATION

INDOOR MODELS

THE MINIMUM CLEARANCES FROM COMBUSTIBLE MATERIAL ARE AS FOLLOWS

CONTROL SIDE	-	WIDTH OF UNIT
OPPOSITE CONTROL SIDE	-	6 INCHES
TOP OF UNIT	-	6 INCHES
BOTTOM	-	0 INCHES

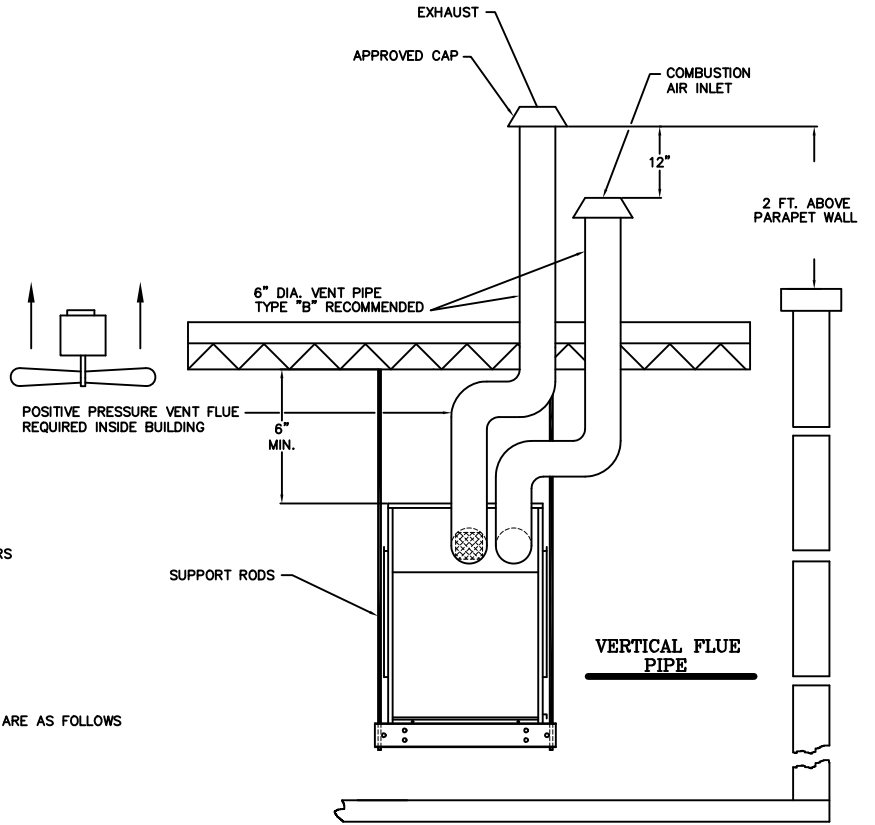

HORIZONTAL FLUE PIPE

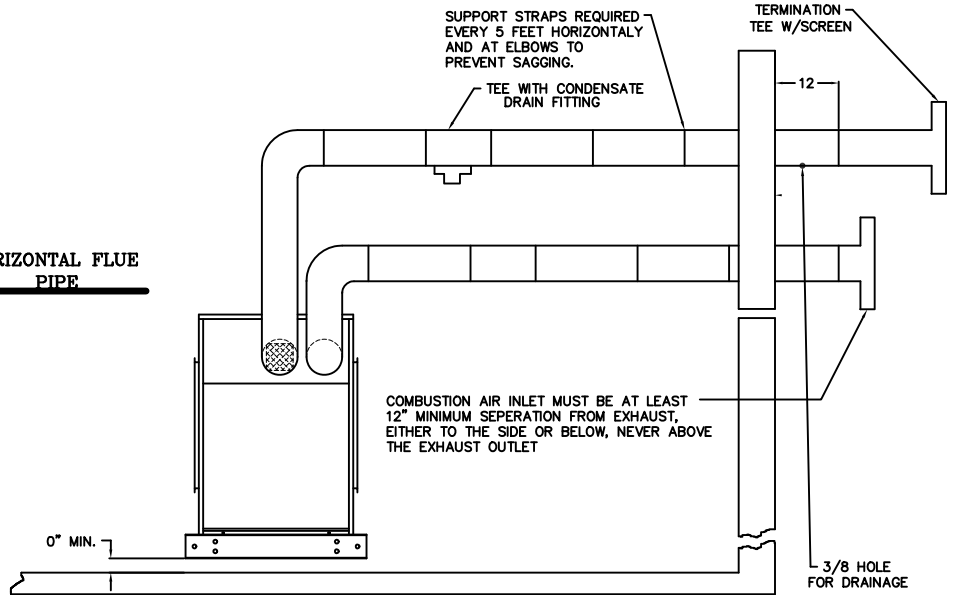

"VENTING"
INDOOR DUCT HEATER
OR INDOOR HEATING-HEATING/COOLING SYSTEMS

INSTALLATION

**VERTICAL/HORIZONTAL
FLUE PIPE**

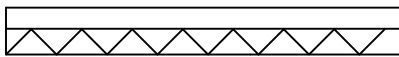

IF EXHAUST FAN IS USED DURING THE HEATING SEASON
 PROVIDE ADEQUATE "MAKE-UP" AIR AND COMBUSTION
 AIR.

INSTALL IN AIRPLANE HANGARS IN ACCORDANCE WITH
 CURRENT NFPA NO. 409 STANDARD ON AIRCRAFT HANGARS
 AND IN PUBLIC GARAGES IN ACCORDANCE WITH CURRENT
 NFPA NO. 88 STANDARD FOR GARAGES. SEE PAGE 4 FOR
 DETAILS.

CLEARANCES/INSTALLATION

INDOOR MODELS

THE MINIMUM CLEARANCES FROM COMBUSTIBLE MATERIAL ARE AS FOLLOWS

CONTROL SIDE	-	WIDTH OF UNIT
OPPOSITE CONTROL SIDE	-	6 INCHES
TOP OF UNIT	-	6 INCHES
BOTTOM	-	0 INCHES

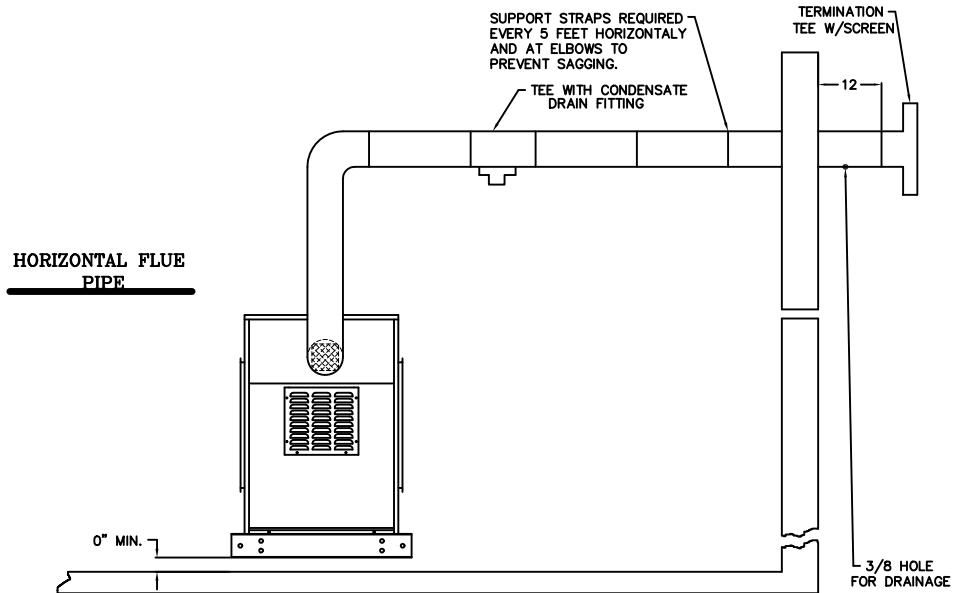
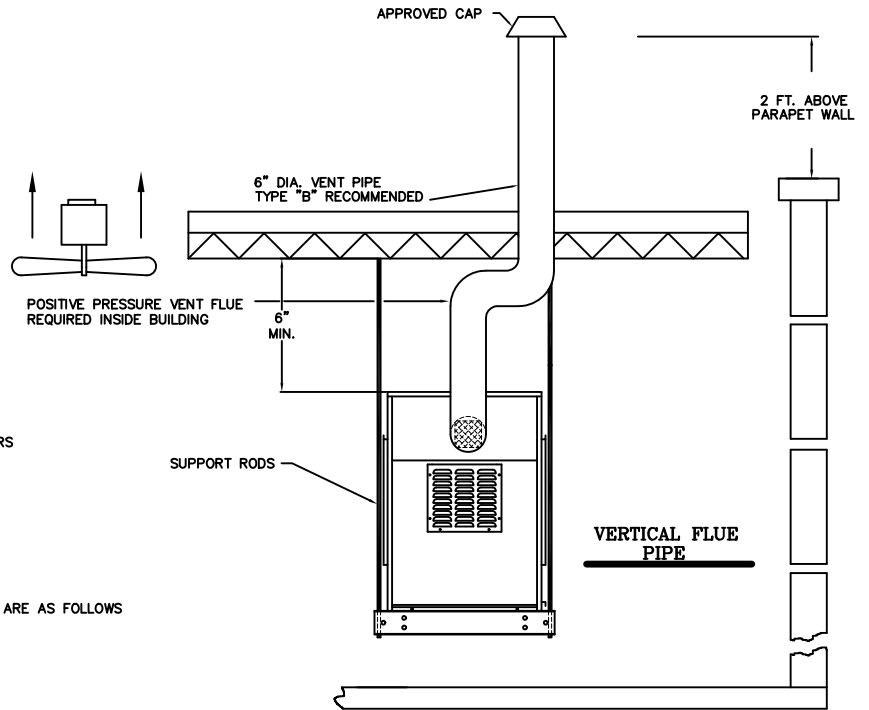

TABLE II

(I) AND(IS) HORIZONTAL FLUE SIZING		
Input in 1000's BTU Hr.	Flue Pipe Diameter	Maximum Length of Flue Pipe
100	4.0 IN	82.0 FT
125	4.0 IN	82.0 FT
160	4.0 IN	82.0 FT
210	6.0 IN	72.0 FT
250	6.0 IN	72.0 FT
300	6.0 IN	72.0 FT
400	6.0 IN	72.0 FT

The instructions for the installation of the venting system shall specify that the horizontal portions of the venting system shall be supported to prevent sagging; the methods of and intervals for support shall be specified. these instructions shall also specify that the venting system:

1. For a category II appliance, have a horizontal run(s) sloping upwards not less than ¼ in./ft. (21 mm/m) from the appliance to the vent terminal
2. For Category II and IV appliances, be installed so as to prevent accumulation of condensate; and
3. For Category II and IV appliances, where necessary, have means provided for drainage of condensate.

Gas Supply:

NOTE: PIPING MUST CONFORM TO STANDARDS OF THE NATIONAL BOARD OF FIRE UNDERWRITERS, CAN/CGA B149 AND ALL APPLICABLE GOVERNING CODES. INSTALL MANUAL MAIN SHUT-OFF VALVE UPSTREAM OF APPLIANCE GAS TRAIN, OUTSIDE OF THE CONFINES OF THE APPLIANCE IN ACCORDANCE WITH CURRENT INSTALLATON CODES.

1. Suggested pipe sizing for direct line from meter or propane tank is found in Table III. These sizes are based on 6" to 7" w.c. pressure at the meter for natural gas; 11" w.c. for propane gas, with .3" w.c. pressure drop schedule 40 pipe and fittings.

TABLE III

Input in 1000's BTU Hr.	Maximum Distance from Meter	Natural*	Propane*
100 to 125	50 feet	¾"	½"
	100 feet	1"	¾"
150 to 175	60 feet	1"	¾"
	100 feet	1 ¼"	1"
200 to 250	30 feet	1"	¾"
	120 feet	1 ¼"	1"
	250 feet	1 ½"	1 ¼"
300	75 feet	1 ¼"	1"
	200 feet	1 ½"	1 ¼"
400 to 420	50 feet	1 ¼"	1"
	100 feet	1 ½"	1 ¼"
500	35 feet	1 ¼"	1 ¼"
	80 feet	1 ½"	1 ¼"
600	300 feet	2"	2"
	50 feet	1 ½"	1 ¼"
800	200 feet	2"	2"
	30 feet	1 ½"	1 ¼"
1000	125 feet	2"	2"
	80 feet	2"	2"
1200	200 feet	2 ½"	2"
	50 feet	2"	2"
1600	150 feet	2 ½"	2 ¼"
	30 feet	2"	2"
	80 feet	2 ½"	2 ½"
	250 feet	3"	3"

The BTU input and output of these systems are listed in Table IV. See page 10.

*On units receiving inlet gas pressure in excess of 14" w.c., a high gas pressure regulator must be provided for each heater section.

2. For larger installations or longer piping runs, consult gas company.

3. If more than ½ PSIG (14 in. W.C.) pressure is available, a high pressure regulator would be required. Pipe sizing may be reduced. On heating systems with more than one duct furnace, multiple high gas pressure regulators may be required.
4. Refer to items (3) and (4) of INSTALLATION PRECAUTIONS.
5. Pipe joint compound should be resistant to the action of L.P gas.
6. Install a DIRT TRAP (tee, nipple, and cap) at connection to each furnace.
7. For ease of servicing, an additional union and manual gas valve should be installed adjacent to the furnace exterior. An approved, readily accessible manual gas valve should be joined to a ground joint type union immediately upstream and connected to the appliance manifold piping.
8. A 1/8 N.P.T. plugged tapping, accessible for test gage connection, must be installed immediately upstream of the gas supply connection to the appliance.
9. The furnace must NOT be operated without a leak limiting orifice installed in the unit pressure regulator vent, if applicable.
10. The appliance and its individual shutoff valve must be disconnected from the gas supply piping system during any pressure testing of that system at test pressures in excess of ½ PSIG.
11. The appliance must be isolated from the gas supply piping system by closing its individual manual shutoff valve during any pressure testing of the gas supply piping system at test pressures equal to or less than ½ PSIG.

NOTE: CHECK ALL GAS CONNECTIONS FOR LEAKS. A SOAP SOLUTION SHOULD BE USED FOR THIS PURPOSE. NEVER USE A TORCH OR FLAME OF ANY KIND.

TABLE IV

Unit	BTU/Hr. Input per Heater	Total BTU/Hr. Input	Total BTU/Hr.* Output
(IH) (ISH) (H) HRDV – 100	100,000	100,000	76,000 (80,000)
(IH) (ISH) (H) HRDV – 125	125,000	125,000	95,000 (100,000)
(IH) (ISH) (H) HRDV – 160	160,000	160,000	121,600 (128,000)
(IH) (ISH) (H) HRDV – 210	210,000	210,000	159,600 (168,000)
(IH) (ISH) (H) HRDV – 250	250,000	250,000	190,000 (200,000)
(IH) (ISH) (H) HRDV – 300	300,000	300,000	228,000 (240,000)
(IH) (ISH) (H) HRDV – 400	400,000	400,000	304,000 (320,000)
(IH) (ISH) (H) HRDV – 600	300,000	600,000	456,000 (480,000)
(IH) (ISH) (H) HRDV – 800	400,000	800,000	608,000 (640,000)
(IH) (ISH) (H) HRDV – 200	100,000	200,000	152,000 (160,000)
(IH) (ISH) (H) HRDV – 250	125,000	250,000	190,000 (200,000)
(IH) (ISH) (H) HRDV – 320	160,000	320,000	243,200 (296,000)
(IH) (ISH) (H) HRDV – 420	210,000	420,000	319,200 (336,000)
(IH) (ISH) (H) HRDV – 500	250,000	500,000	380,000 (400,000)
(IH) (ISH) (H) HRDV – 600	300,000	600,000	456,000 (480,000)
(IH) (ISH) (H) HRDV – 800	400,000	800,000	608,000 (640,000)
(IH) (ISH) (H) HRDV – 1000	250,000	1,000,000	760,000 (800,000)
(IH) (ISH) (H) HRDV – 1200	300,000	1,200,000	912,000 (960,000)
(IH) (ISH) (H) HRDV – 1600	400,000	1,600,000	1,216,000 (1,280,000)

* All (I), (IS) and (H) series units are 80% efficient

OPERATION

When the unit is in the winter mode, the fan is on bringing outside and/or return air into the building. The furnace is on and maintaining a discharge temperature as indicated by the Maxitrol Selectra dial (Example 73° F) and the Maxitrol gas valve is modulating. If the discharge temperature exceeds the dial set point, the Maxitrol amplifier will indicate to shut the ignition system off. When the temperature starts to cool the Maxitrol sensor just below set point, the amplifier will indicate to reestablish ignition. This will maintain a steady discharge temperature even on days where outside temperature is within a few degrees of set point.

With the override option, a room thermostat would be set approximately 5° F above the discharge dial set point thus allowing a lower modulating set point and saving fuel (Example discharge dial set point 67° F – room thermostat 72° F). When the thermostat calls for a heat increase in the space, a relay closes and connects two terminals on the amplifier causing the Maxitrol system to put the main burner at high fire. This will last as long as it takes for the room thermostat to satisfy and open. Because the discharge temperature is now above the discharge dial set point, the burner will shut off until the temperature is within the set point of the discharge dial. The unit will go back to its modulating mode.

VALVE ADJUSTMENTS

(See bulletin MT2035 for additional M/MR valve information)

Note: High Fire Adjustment should be checked whenever Low Fire Adjustment is changed.

Disconnect wire from amplifier terminal 3, remove cover plate (2).

High Fire Adjustments:

- (A) Using the maximum adjustment screw (4), set manifold pressure to furnace manufacturer's specifications.
- (B) Replace cover plate (2) on Modulator-Regulator valve and reconnect wire to amplifier terminal 3.

Low Fire Adjustments:

- (A) Remove maximum adjusting screw (4), spring (5), and plunger (8). A small magnet is useful for this purpose.
CAUTION: The plunger is a precision part. Handle carefully to avoid marring or picking up grease and dirt. Do not lubricate.
- (B) Using minimum adjusting screw (9), set manifold pressure to furnace manufacturer's specifications.
- (C) Replace plunger and spring retainer, spring, and maximum adjusting screw in proper order.

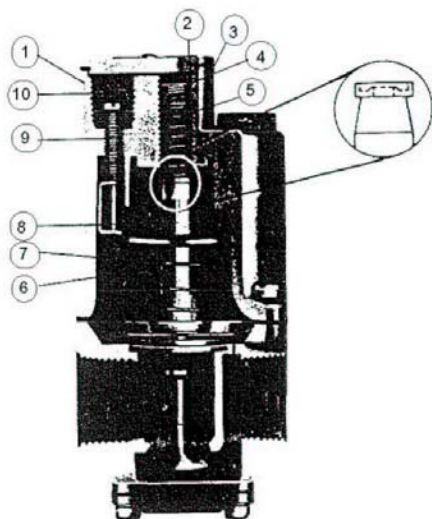

- 1. TOP HOUSING
- 2. COVER PLATE
- 3. SEAL GASKET
- 4. MAXIMUM ADJUSTMENT SCREW
- 5. MAXIMUM ADJUSTMENT SPRING
- 6. SOLENOID
- 7. MINIMUM ADJUSTMENT SPRING
- 8. PLUNGER
- 9. MINIMUM ADJUSTMENT SCREW
- 10. MINIMUM ADJUSTMENT SCREW STOP

ELECTRONIC IGNITION:

All (I) (IS) HRDV series furnaces are equipped with a solid state design, intermittent pilot ignition system. This electronic system consists of an ignition control module, combination pilot burner/igniter-sensor (sensor or flame rod) assembly, and igniter-sensor lead. Activated by the unit's 24V transformer and controlled by a field installed thermostat or controller, the module will first perform a safe-start check which tests its internal components for a false pilot flame condition. If satisfactory, the module then energizes the pilot gas valve to open and generates 15,000 V peak capacitive discharge ignition spark to ignite pilot burner. When pilot is established, the flame monitoring circuit of the module responds to the presence of flame detected by the flame rod and discontinues ignition spark. The main gas valve is then energized to open, pilot lights main burners, and burner operation continues until call for heat is satisfied. The module then deactivates both pilot and main gas valves and the unit shuts down.

Two types of ignition control modules are utilized. A non 100% shutoff design is used with natural gas ONLY. It provides continuous spark for pilot ignition, but if pilot does not light, trouble must be isolated and corrected. A 100% shutoff design may be used for natural and L.P. gas. It provides a 90 second gas trial for pilot ignition. If pilot does not light within the trial time, the module deactivates pilot valve (100% safety lockout) but continues spark for pilot ignition. This system may be reset at the thermostat or controller and trial for ignition resumed. If pilot still fails to ignite, trouble must be isolated and corrected.

Preliminary Circuit Analysis

In order to diagnose the cause of problems in this system, it is necessary to determine certain values. It is helpful to have an AC and DC voltmeter and an ohmmeter capable of reading 0 to 15,000 ohms. For ease in troubleshooting, it is necessary to rewire the system, replacing the discharge air sensor with a 4500 ohm, ½ watt test resistor.

Modulating Function Test:

Connect a DC voltmeter to amplifier terminals 1 and 2. If more convenient, the meter may be attached to the MR valve terminals. Rotate temperature selection knob to maximum setting – the DC volts should read zero. The voltage should gradually increase to at least 20 volts when the temperature selector is slowly rotated to its minimum (generally over a 3° to 4° range).

Automatic Valve Function:

After the electronic modulation function is tested, a voltage reading must be taken across the automatic gas valve. These voltage readings will be approximately 24 V AC with the temperature selection knob at maximum setting, zero volts AC with the selector at minimum setting. The relay switching action should occur when the modulating voltage is between 15 and 19V DC.

If these voltage readings are observed as noted, it is proved that the amplifier and temperature selector are operating properly.

After testing, remove the resistor and reconnect the discharge air sensor.

Maintenance

CLEANING:

NOTE: SOOT, DIRT, ETC. WILL PREVENT PROPER COMBUSTION. FOR NORMAL AIR CONDITONS, CLEAN UNIT PRIOR TO HEATING SEASON WITH A PERIODIC INSPECTION AT LEAST ONCE A MONTH THROUGHOUT THE DURATION OF THE SEASON AND CLEAN AS NECESSARY. IN HEAVILY CONTAMINATED AREAS, INSPECTION AND POSSIBLE CLEANING MAY BE REQUIRED MORE FREQUENTLY DURING THE HEATING SEASON. CLEAN FLUE TUBES, BURNERS AND PILOT BEFORE THEY BECOME BADLY FOULED.

• Cleaning Flues:

1. Outdoor units:

- a. Remove burner drawer assembly. To accomplish, close manual gas valve to unit and break main gas supply at union. Cut furnace electrical supply. Unscrew the two quick fasteners at the bottom of the control access panel. Pull bottom of panel away slightly and allow panel to drop. Remove panel and disconnect applicable electric wiring. Remove retaining "L" tab at the end of the burner drawer and slide drawer assembly out of the furnace.
- b. Remove the screws holding top panel and lift panel off.
- c. Remove the screws from bottom flange of the collector box cover and lift cover off.
- d. Remove the screws from bottom flange of the collector box. Remove the two screws from the venter motor support at the right heater leg and disconnect the three conductor cables at the junction box. Lift collector box off. (Power venter assembly will remain attached to the collector box.)
- e. Lift flue baffles from tubes.
- f. Clean the inner surfaces of flue tubes using a 1-1/2" or 1-3/4" long-handled wire brush. Clean and replace flue baffles.
- g. Remove dirt from bottom pan and clean burners before replacing drawer assembly. (Be sure to reinstall "L" tab after drawer assembly is installed in the heater.)

1. Indoor Units:

- a. Disconnect exhaust flue from unit flange.
- b. Disconnect separated combustion air flue from unit flange (IS models only).
- c. Remove the (4) screws holding the top portion of the burner control vestibule door around the power venter outlet.
- d. Remove burner control vestibule door by turning bottom latches on door.
- e. Pull the door away by pulling the bottom rail on the door outward.
- f. On some models a (2) piece door is provided. (2) screws hold the top portion of the door in place. Remove screws and remove top door portion.
- g. Remove burner drawer assembly. To accomplish, close manual gas valve to unit and break main gas supply at union. Cut furnace electrical supply. Unscrew the two quick fasteners at the bottom of the control access panel. Pull bottom of panel away slightly and allow panel to drop. Remove panel and disconnect applicable electric wiring. Remove retaining tabs at each end of the burner drawer and slide drawer assembly out of the furnace.
- h. Remove the screws holding top panel and lift panel off.
- i. Remove the screws from bottom flange of the collector box cover and lift cover off.

- j. Remove the screws from bottom flange of the collector box. Remove the two screws from the venter motor support at the right heater leg and disconnect the three conductor cables at the junction box. Lift collector box off. (Power venter assembly will remain attached to the collector box.)
- k. Lift flue baffles from tubes
- l. Clean the inner surfaces of flue tubes using a 1-1/2" or 1-3/4" long-handled wire brush. Clean and replace flue baffles.
- m. Remove dirt from bottom pan and clean burners before replacing drawer assembly. (Be sure to reinstall "L" tab after drawer assembly is installed in the heater.)

• Cleaning Burners:

1. Burners can be removed from drawer assembly by raising front of burner, pushing burner forward against the hold-down clip until venturi end of burner is free of support. Remove burners next to pilot last and replace these burners first.
2. Remove ribbon cotter pin and carefully pry ribbon from slot.
3. Clean ribbon with brush and blow off dust.
4. Replace ribbon and cotter pin.
5. Replace burners, making certain that they seat properly in place.
6. Failure to re-seat burner assemblies properly could result in fire, explosion, equipment damage or death.

• Cleaning Pilot:

1. Disconnect tubing from pilot body, remove igniter lead and detach pilot burner assembly from support.
2. Remove pilot orifice fitting.
3. Using a small brush, clean pilot burner assembly, orifice, and flame rod. Blow off loose particles.
4. Assemble and install in original position.
5. Adjust pilot flame to surround flame rod tip about 3/8". Flame must be soft – not hard, noisy, or yellow.

• Additional Maintenance Procedures:

1. Motors should be relubricated according to the manufacturer's lubrication instructions.
2. Filters must be cleaned (cleanable type) or replaced (throw-away type) with like filters as often as necessary so as not to restrict air delivery.
3. Twice a year check belts and sheaves for alignment and belt tension.
4. When a belt is replaced, shorten center distance between sheaves by loosening motor bolts and sliding motor on support. On units requiring multiple belts, use a matched set.
5. The following procedure is recommended for tensioning belts:
 - A. Measure span length "X" shown in Figure I.
 - B. At the center of span length "X", apply a force perpendicular to the span and large enough to deflect belt 1/64" for each inch of span length.
Example – The required deflection for a 40" span would be 40/64" or 5/8".
 - C. Compare the force applied with the values given in Table V. If force is between the minimum and maximum range shown, the drive tension should be satisfactory. A force below the minimum value indicates an undertensioned belt and a force that exceeds the maximum value indicates an overtensioned belt.
6. Lubricate main fan bearing with a high grade lithium base grease. Perform at least every quarter (three months) or schedule according to equipment use.

TABLE V

Belt Cross Section (marked on belt)	Motor Pulley Pitch Diameter	Deflection Force	
		Minimum	Maximum
A	3.0" – 3.6"	2.62 lbs.	3.25 lbs.
	3.8" – 4.8"	3 lbs.	4 lbs.
	5.0"- 7.0"	3.25 lbs.	5 lbs.
B	3.4" – 4.2"	3 lbs.	5 lbs.
	4.4" – 5.6"	4 lbs.	5.87 lbs.
	5.8" – 8.6"	5.25 lbs.	7.87 lbs.

FIGURE I

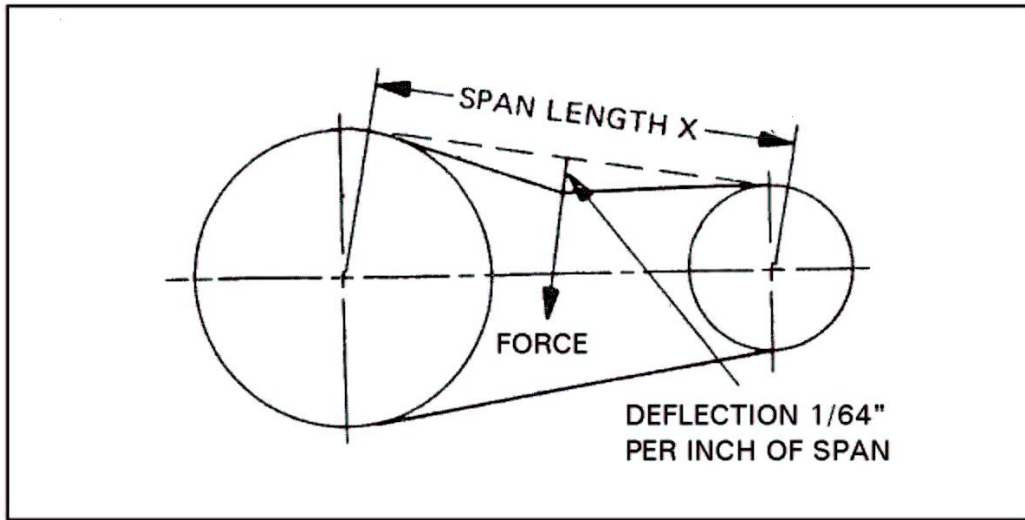

LUBRICATION INSTRUCTIONS FOR MOTORS

Some small motors have sealed-for-life bearings which require no relubrication. Regreasable bearings are shipped with a high quality, wide temperature range grease in the bearings.

Motors can be regreased by stopping the motor, removing drain plug and pumping new grease into fill hole. Run motor with drain plug removed until excess grease has been discharged (minimum 10 min.). Stop motor and replace drain plug.

Units that operate at speeds greater than 1800 RPM should be lubricated on a more frequent maintenance schedule depending on duty cycle. Use a low pressure grease gun and avoid overgreasing.

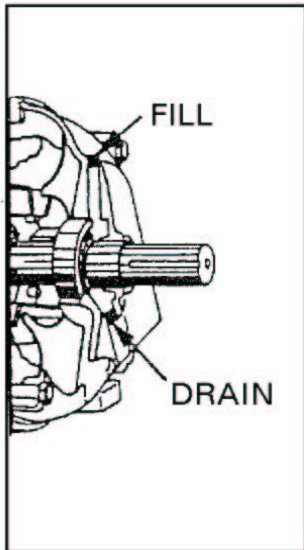

SUGGESTED REGREASING INTERVALS			
SERVICE	MOTOR HORSEPOWER		
	UNDER 50	50-100	100 UP
A	3-5 Yrs.	2-4 Yrs.	2 Yrs.
B	2-4 Yrs.	1-1/2 Yrs.	1-1/2 Yrs.
C	1-2 Yrs.	1 yr.	6 Mos.
D	4 Mos.	4 Mos.	3 Mos.
SERVICE SYMBOL	TYPE OF SERVICE		
A	Infrequent operation or light duty in clean atmosphere.		
B	8-16 Hrs. / Day in clean, relatively dry atmosphere.		
C	12-24 Hrs./Day, heavy duty, or if moisture is present.		
D	Heavy duty in dirty, dusty locations; high ambients; moisture laden atmosphere; vibration.		

Recommended Greases:
Use the following greases or equivalent grease unless a special grease is specified on the nameplate.

MANUFACTURER
CHEVRON
SHELL

TRADE NAME
SR/#2
DOLIUM R

TROUBLE SHOOTING:

NATURE OF TROUBLE

CORRECTIVE MEASURES

· Pilot Fails to Light, Flame Burns Erratically , or Goes Out:

- | | |
|---|---|
| 1. Improper (too high or low) gas pressure at unit. | Make sure all manual gas cocks are open. Check gas pressure at main valve to be certain it conforms to MINIMUM SUPPLY PRESSURE marked on the specification plate. In any case, pressure is NOT to exceed 14" W.C. for natural or L.P. gas. Regulate gas pressure or change supply pipe size to maintain proper inlet pressure. Regulate gas pressure or change supply pipe size to maintain proper inlet pressure. Adjust pilot flame to surround end of flame rod about 3/8 inch |
| 2. Obstruction in pilot line or orifice. | See CLEANING instructions. |
| 3. Inoperative pilot gas valve or valve operator. | Check all manual gas cocks. Inspect wiring/ connections Between ignition module and pilot valve or operator. Correct as necessary. Check low voltage across PV and V/PV terminals on module. If previous inspections are satisfactory, replace pilot valve or operator. If no or inadequate voltage is detected on module test, replace module. |
| 4. No or inadequate spark across igniter-sensor gap. | Check for line voltage, low voltage power supply and transformer, all wiring connections, improper ground, blown fuse in ignition module if applicable, faulty high limit switch, voltage leaks in igniter lead or cracked flame rod insulator, and proper igniter-sensor gap (approximately 1/8"). Correct as necessary. If igniter still does not spark, replace ignition module. |
| 5. Improper pilot. Flame either too small or flame "lifts." | If pilot is too small, clean pilot line, primary air openings, and pilot orifice. If flame lifts, reduce gas pressure. For both conditions, adjust pilot flame to surround end of flame rod about 3/8". Flame must be soft and quiet. |
| 6. System goes into "safety lockout." (100% lockout models ONLY.) | Reset thermostat/controller and try again for ignition. To reset, adjust thermostat to a point below room temperature or switch off controller. Wait for a minimum of 60 seconds then adjust thermostat above room temperature or switch controller on. If ignition is not made within the 90 second trial period, the system goes into safety lock-out again. Check gas supply, line and low voltage supply, ground limit switch, all wiring/connections, ignitions module and gas valves. Correct as necessary. |

· Venter Running But No Spark Or Pilot

- | | |
|------------------------------------|---|
| 1. Vent proving switches not made. | Replace Venter motor (end switch).
Replace vent proving air switch.
Improve venting practices.
Improve on negative pressure in room.
Replace ignition wire.
Replace ignition control module. |
|------------------------------------|---|

· Pilot Lights But Ignition Spark Continues:

- | | |
|---|--|
| 1. Pilot flame does not contact flame rod sufficiently. | Adjust pilot to surround end of flame rod about 3/8". Flame must be soft and quiet. |
| 2. Faulty flame rod, igniter lead, ground wire/ connections or inoperative ignition module. | If a problem develops in the flame sensing circuit, pilot flame may NOT be detected to conduct a flame sensing current even though high voltage ignition spark is satisfactory. If the flame rod is faulty and cleaning does not correct, the igniter/burner assembly must be replaced. Inspect and correct as necessary igniter lead and ground wire/connections. If ignition continues to spark, replace module. |

NATURE OF TROUBLE

CORRECTIVE MEASURES

• **Main Burners Fail to Light:**

1. Faulty high limit switch or blocked vent limit switch. Stuck in open position. Replace high limit switch or blocked vent limit switch. Check venting.
2. Pilot flame too small See item 5 of "Pilot Fails to Light" in this section.
3. Improper (too high or low) gas pressure at unit. See item 1 of "Pilot Fails to Light" in this section.
4. Faulty flame rod, igniter lead, ground wire/connections, or inoperative ignition module. See item 2 of "Pilot Lights But Ignition Spark Continues" in this section. To test ignition module, check low voltage across MV and MV/PV terminals. If no or inadequate voltage is detected, replace module. If voltage is satisfactory, inspect main gas valve.
5. Inoperative main gas valve. Check all wiring/connections between ignition module and main gas valve and correct as necessary. If module and wiring inspections are satisfactory, replace main gas valve or valve operator.

• **Main Burners Shutdown Before Call for Heat Is Satisfied:**

1. Faulty limit switch. Replace limit switch.
2. Interrupted gas supply to unit or faulty main gas valve. Check gas supply. Inspect main gas valve for proper operation. Replace main valve or operator as necessary.
3. Faulty system ground, flame sensing circuit, or wiring/connections. If ground is poor, nuisance shutdowns may occur occasionally even though burner operation is normal at the time of an inspection. Test continuity of igniter lead and ignition module ground wire. Correct as necessary. Inspect flame rod. Clean or replace if needed. Check and correct wiring/connections between module and main gas valve.
4. System goes into "safety lockout." (100% lock-out models ONLY.) See item 6 of "Pilot Fails to Light" in this section
5. Faulty ignition module. If all previous checks are satisfactory and burners continue to shut-down, replace module.

• **Call for Heat Ends, But Main Burners Continue Operation:**

1. Faulty thermostat/controller or short circuit in respective wiring. Repair or replace.
2. Main gas valve stuck in open position or inoperative module. Remove MV lead at ignition module. If valve does not close, replace valve or operator as necessary. If main gas valve and thermostat/controller are okay, replace module.

• **Delayed or Rough Ignition:**

1. Obstruction in main burner spuds. Remove spuds, clean, and replace.
2. Burners covered with foreign matter. Clean burners. See CLEANING on pages 12 and 13.

• **Burner Flames Flashback and Burning at Spuds:**

1. Gas input too low. Adjust pressure regulator or increase supply pipe size to unit. It may be necessary to consult gas company.
2. Burners or flue tubes covered by foreign matter. See CLEANING on pages 12 and 13. If faulty, consult manufacturer.

• **Burner Flames Are Yellow or Tend to "Float" under Flue Tubes:**

1. Gas input too high due to oversize main burner spuds or gas supply pressure in excess of 8 ounces (approximately 14" W.C.) Consult manufacturer for proper spud size before changing or gas company before adjusting regulator or decreasing size of supply piping to unit.
2. Dirty burner ribbons or flue tubes. See CLEANING on page 12 and 13.
3. Insufficient combustion air. Make sure air inlets of unit are open. Clean unit. If condition still exists, see item 1 of INSTALLATION PRECAUTIONS.

NATURE OF TROUBLE

CORRECTIVE MEASURES

• Blower Fails to Operate within 2 Minutes after Burners Ignite:

- | | |
|--|--|
| 1. Faulty blower wiring/connections, motor, or fan controls. | Inspect and correct wiring/connections as necessary. Connect line voltage directly to motor. If motor operates, replace fan control if non-adjustable. |
| 2. Thermostatic fan control. | See modulating or two-stage gas controls, item 10 of INSTALLATION PRECAUTIONS. |

• Insufficient Heat Delivery from Furnace:

- | | |
|--|--|
| 1. Undersized spuds or manifold pressure below marking on specification plate. | Consult manufacturer for proper spud size before changing or gas company before adjusting regulator. Be sure gas supply pipe size to unit is adequate. |
| 2. Inadequate air delivery from blower. | Check for slipping belts and proper blower speed, plugged filters (if used), dirty blower impeller blades, or any airflow obstructions and excessive system static pressure. Correct as necessary. |
| 3. Dirty flue tubes. | Clean tubes. See CLEANING on page 12 and 13. |

• Furnace Overheats or Cycles on Limit Switch:

- | | |
|---|--|
| 1. Main gas valve faulty. Stuck in open position. | Replace main valve or operator. |
| 2. Faulty limit switch or fan control (if used). | Inspect and replace as necessary. |
| 3. Blower motor cutting out on overload. | Check for high or low voltage. Check for faulty motor or motor overload. |
| 4. Inadequate air delivery from blower. | See item 2 of "Insufficient Heat Delivery" in this section. |
| 5. Poor air flow patterns through furnace. | See ILLUSTRATIONS on page 11. |

• Resonance on L.P. Gas Units:

1. Reduce gas input slightly. If condition persists, consult manufacturer.

• Modulating or Two-Stage Gas Controls:

1. Consult manufacturer.

I. TECHNICAL SERVICE

Periodic service on any piece of mechanical equipment is necessary for efficient operation. If a service problem arises, Hastings HVAC, Inc. has a technical service organization available to provide professional assistance to help you with a solution to that problem. Two inbound Watts lines to the home offices enables you to consult with qualified factory service personnel. For needed parts, appliance data, or assistance on a service problem, contact the service department of Hastings HVAC, Inc. Also, when ordering replacement parts, be sure to specify the following:

1. Model and serial number of unit.
2. Type of gas or fuel.
3. Make of electric valve and voltage.

To contact Hastings HVAC, Inc. Service Department, outside of Nebraska call (800) 228-4243 or 228-4270 or write Hastings HVAC, Inc., 3606 Yost Avenue, Hastings, Nebraska 68901-1966. Telephone (402) 463-9821.



3606 Yost Avenue · Hastings, Nebraska 68901-1966

Phone (402) 463-9821 · Fax (402) 462-8006

www.hastingshvac.com

E-mail: sales@hastingshvac.com