

ADDENDUM

NOTE: A low-temperature limit control is recommended in areas where freeze-up protection is needed in the event of burner shutdown.

NOTE: Install heater such that the ignition control system is not directly exposed to water spray, rain or dripping water.

NOTE: If not supplied by the factory, provide an electric switch having adequate ampacity (see specification plate on heater for voltage and ampacity) and shall be installed in accordance with Article 430 of the National Electrical code, ANSI/NFPA 70.

NOTE: Refer to markings on heater control box for locations for field installed wiring and control wiring.

NOTE: Refer to heater rating plate for determining the minimum gas supply pressure for obtaining the maximum gas capacity for which this heater is specified.

Page 3

INSTALLATION

DUCT CONNECTIONS

Indoor/Outdoor units with a vertical – upblast discharge arrangement must have discharge ductwork supported from building support members and not supported from the equipment. NO DISCHARGE DUCTWORK IS TO BE SUPPORTED BY EQUIPMENT DISCHARGE OPENING CONNECTIONS.

GENERAL INFORMATION

FACTORY FLAME TEST

All Hastings heaters are given a complete flame test and safety control check-out before shipping. A copy of the flame test report is available upon request.

CHECK-UP ON ARRIVAL

All heaters are thoroughly checked by a shipping inspector before they are accepted by the carrier. Upon arrival the heater should be inspected by the customer. If any damage has occurred in transit, an immediate claim should be filed with the carrier. Due to the widely varying conditions under which heaters are transported to the job, unloaded and installed, it is impossible for Hastings to assume responsibility for handling in transit. Check to see if unmounted items are included with shipment.

HANDLING THE HEATER

The heater has lifting lugs for crane hook-up. Hooks, jacks, or chains must not be applied around casing or control box.



INSTALLATION

POSITIONING THE HEATER

Heater should be installed so that it is level. Allow 48" clearance at the front and control side of the heater and 18" on the bottom, top and other side. Air intake to the unit should not be restricted in any manner.

WIRING

Electrical connections must be in accordance with all local and national codes.

PIPING

Gas piping should be sized adequately, in accordance with the American National Standard Fuel Gas Code Z223.1.



TYPICAL OPERATING SEQUENCE

Blower switch should be turned on to start the fan. Placing season switch in winter position energizes the gas control system. If all limit switches are satisfied, the pilot valve will be opened and pilot gas automatically spark ignited. When the flame sensor senses the pilot flame, the main valve will be opened through terminals on the flame safeguard relay. The modulating gas valve will control the flow of gas to the burner to maintain the discharge temperature. The controller should be set for the desired discharged temperature. A representative schematic wiring diagram and legend are included in this manual.

START-UP INSTRUCTIONS

After the heater has been positioned and all service connections made, complete the following check-up before starting the unit. Keep in mind the fact that the heater may have been subject to severe jolts during transportation and handling. The check-up is essential to make sure that the heater is in the same operating condition as it was at completion of the factory flame test.

1. Make sure all field wiring and gas piping are in accordance with local and national codes. Check incoming power—making sure it is the same as the nameplate voltage.
2. Close gas hand valves and pilot cock.
3. Set all switches to “Off” position.
4. Wait five minutes.
5. Push reset button on electronic relay.
6. Push manual reset button on gas pressure switches, starters, and limit control if necessary.
7. The unit is equipped with a modulating gas valve which is controlled by a discharge sensor located in the discharge opening. Check to see that the sensor is properly positioned. Set the selector dial for desired discharge temperature.
8. Check if limit control is locked at 120 deg. F. discharge temperature.
9. Check all gas piping for leaks.
10. Turn on main power.
11. Before firing the burner, check the motor, belts and pulleys for proper adjustment, etc. Turn the blower switch on and run the fans. Check the current draw of the motor.
12. If the motor current is excessive, adjust the variable speed pulley (standard through 10 hp) on the motor to lower the amp draw on the motor. **Caution:** Current readings should be taken with the access door in place.
13. Set temperature controller(s) to call for heat.
14. Open hand valve and pilot cock.
15. Set season switch to “Winter” position.
16. The pilot will light and then the main flame will come on.
17. The burner will come on at high fire initially, then gradually modulate down. While the unit is on high fire, check the flame length. It must be approximately 18” beyond end of burner. Check the manifold pressure—should not exceed 2.6 ounces. Check temperature rise and/or gas rate. If too high, set at desired rate: (1) by reducing pressure setting on main regulator or (2) by reducing high fire stop setting on modulating valve. If no high fire adjustment is available, reset modulating control to design temperature rise plus current outdoor temperature to approximate full input. If input is too low, increase setting on main regulator but not past point where no further pressure increase is evident. With burner running, reset modulating control point less than incoming air temperature to drive valve to low fire position. Then gradually reduce low fire stop, or bypass till fire tends to go out. Increase to the smallest stable, full length fire. If a local weak spot appears, check for clogged low fire air ports or extreme turbulence at affected portion. Make low fire adjustments patiently. Due to low gas flow rate, response to adjustments will be slow.

Wiring Diagrams

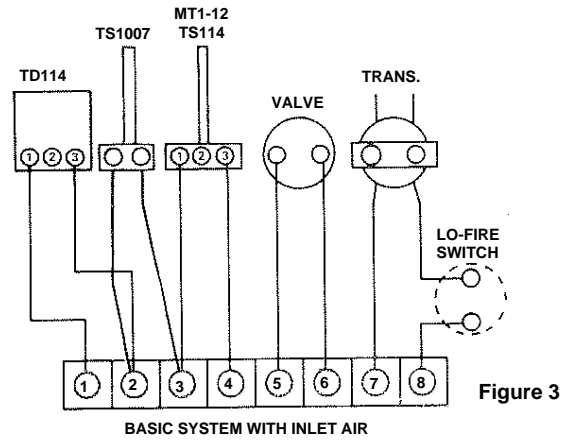
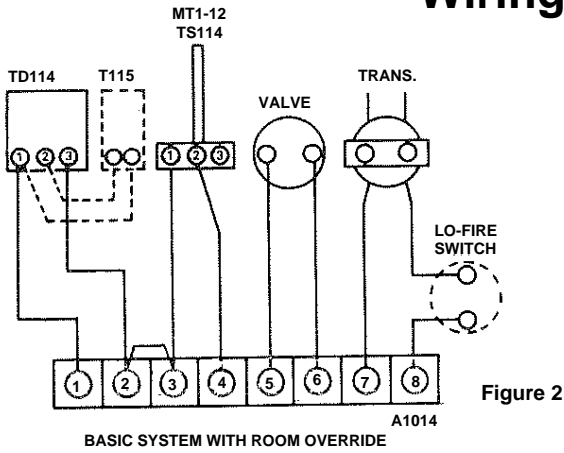

Temperature Calibration-

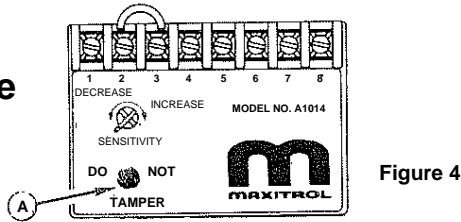

Note: The components of this system are individually calibrated and are not part of a matched set. When it has been positively determined that there is a calibration problem with the entire system the most convenient component may be used to correct the calibration. It is necessary to place an accurate temperature measuring device as near the Discharge Air Sensor as possible. Set the Remote Temperature Selector at least 10 deg. above outside air temperatures.

If calibrating at the Amplifier - adjust calibration potentiometer (A), Figure 4, until temperature reads the same as the set temperature. If the temperature is below the set point, then rotate calibration potentiometer (A) clockwise. If the temperature is above the set point, rotate the potentiometer counter clockwise.

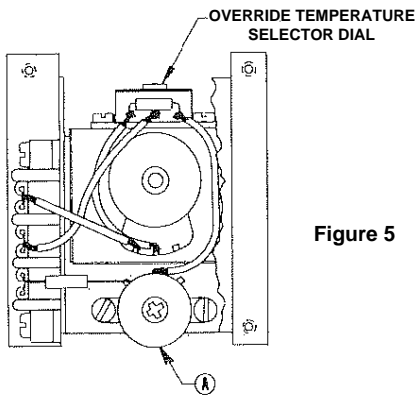

If calibrating the Remote Temperature Selector - if measured temperature is below set temperature, rotate the calibration potentiometer (A), Figure 5, clockwise until the correct temperature is obtained. If the temperature is above the set point, the potentiometer (A) should be turned counter-clockwise.

Proceed slowly with the above steps so as to allow the temperature measuring instrument to catch up with the change in temperature.

Valve Adjustments

Note: Low fire adjustment should be checked whenever the high fire adjustment is changed.

MR 212 Valve - High Fire Manifold Adjustments

1. Disconnect wires from terminal #4 in the Amplifier, Figure 4. This causes the valve to call for continuous high fire.

2. Remove seal cap (A), Figure 6, and turn regulator pressure adjusting screw to obtain desired manifold pressure. (Clockwise rotation increases pressure.)
3. Reconnect the wires to terminal #4.

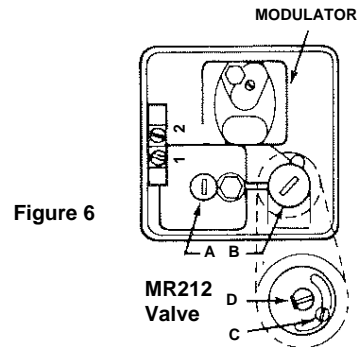

Low Fire or By-Pass Adjustment.

1. Disconnect wire from terminal #8 in the Amplifier, Figure 4, this causes valve to call for continuous low fire.
2. Remove cap (B), Figure 6, and loosen lock screw (C). Turn (D) to desired low fire adjustment. (Clockwise rotation reduces minimum flow rate.)
3. Tighten set screw (C), replace cap (B) and reconnect wire to terminal #8.

M611 Valve - High Fire Manifold Adjustment

1. Disconnect wires from terminal #4 in the Amplifier, Figure 4, this causes the valve to call for continuous high fire.
2. Adjust the pressure regulator to obtain the desired manifold pressure (7" w.c. maximum).
3. Reconnect the wires to terminal #4.

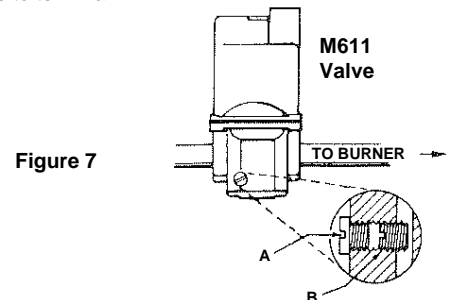

Low Fire or By-Pass Adjustment

1. Disconnect wire from terminal #8 in the Amplifier, Figure 4, This causes valve to call for continuous low fire.
2. Remove cap (A), Figure 7, and turn adjusting screw (B) to desired low fire adjustment. (Use 1/8" Allen Wrench.) For convenience, two adjustment positions are provided on opposite sides of the valve. Usually, the less accessible of these is in the closed position, so the desired setting can be made from the front of the manifold.
3. Replace cap (A), and reconnect wire to terminal #8.

TROUBLE SHOOTING CHART

First make certain of fuel and power supply. A closed hand shut-off valve, blown fuse in main power supply line or burner control circuit is often the cause of trouble. Make sure voltage at the control box is within plus or minus ten volts of that specified. Individual control instruction sheets are provided with unit. These, together with the schematic wiring diagram, should provide the necessary information to find the problem. Some general checks to make are given below.

Nature of Trouble	Possible Causes	Corrective Measures
1. Fans do not operate.	<ol style="list-style-type: none"> 1. No electrical supply. 2. Loose wire leads. 3. Main disconnect switch not fully closed. 4. Blown fuses. 5. Linestarter holding coil defective. 6. Fan motor defective. 7. Starter out on overload 	<ol style="list-style-type: none"> 1. Check entrance cable. 2. Check all fan circuit connections. 3. See that switch knives are fully inserted. 4. Locate and replace. 5. Check terminals with test light. If current is present, replace coil. 6. Replace or repair. 7. Reset.
2. Safety relay does not go through component check after blower starts.	<ol style="list-style-type: none"> 1. Air switch not closing. 2. Burner switch open. 3. Defective relay. 4. Open limit circuit. 	<ol style="list-style-type: none"> 1. Adjust 2. Close. 3. Replace. 4. Adjust—find cause.
3. Pilot does not light	<ol style="list-style-type: none"> 1. Pilot valve defective. 2. Ignition system defective. 3. Flame relay's load relay contacts dirty. 4. Air in gas line. 	<ol style="list-style-type: none"> 1. Check and replace. 2. Check spark gap, ignition cable transformer and cracked insulator on electrode. 3. Clean. 4. Purge
4. Flame relay does not pull in.	<ol style="list-style-type: none"> 1. Flame sensor connection loose. 2. Flame sensor not located properly. 3. Moisture on sensor. 	<ol style="list-style-type: none"> 1. Check and repair or check for cracked insulator. 2. See instructions on flame rod location and set accordingly. 3. Replace.
5. Pilot lights but main burner does not light.	<ol style="list-style-type: none"> 1. Main valve defective. 2. Modulating valve not opening. 3. Defective flame relay. 	<ol style="list-style-type: none"> 1. Check and replace. 2. See Maxitrol Trouble Shooting Guide. 3. Replace.

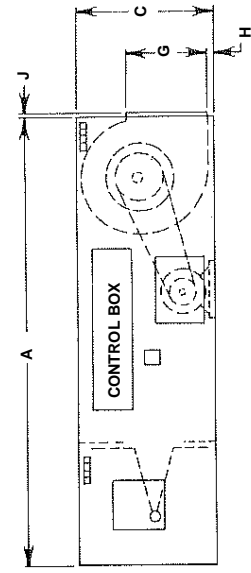

SIDE ELEVATION HR-1

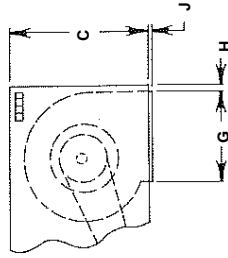

HR-2

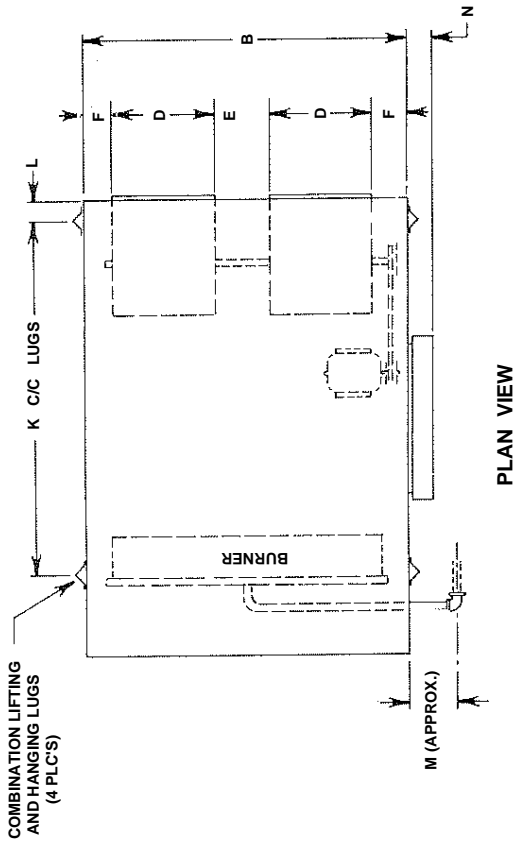

NOTES:

1. INLET OPENING TO BE 1/8 INCH LESS THAN B & C DIMENSIONS.

TABLE OF DIMENSIONS (IN INCHES)

LU UNIT MODEL	A	B	C	D	E	F	G	H	J	K	L	M	N
112	84	30 1/4	25 5/16	15 5/8	-----	7 5/16	13 7/16	3/8	3/16	64 3/4	3 3/8	8 5/8	7
115	84	30 1/4	25 5/16	18 5/8	-----	5 13/16	15 7/8	3/8	3/16	64 3/4	3 3/8	8 5/8	7
215	84	60	25 5/16	18 5/8	11 1/8	5 13/16	15 7/8	3/8	3/16	64 3/4	3 3/8	8 1/2	7
218	90	68 1/8	31 1/4	21 7/8	12	6 3/16	18 7/8	1/8	5/8	70 11/16	3 1/2	12 1/4	7



3606 Yost Avenue · Hastings, Nebraska 68901-1966
Phone (402) 463-9821 · Fax (402) 462-8006
www.hastingshvac.com
E-mail: sales@hastingshvac.com